

MODEL CM-10

Service Observing System

1. GENERAL

- 1.01 The DEES CM-10 is a complete 10 line call monitoring system with integrated talk assist capability. The CM-10 operates with almost any telephone system, providing dial-access to 10 lines or stations from a telephone designated as the observer's station. From that telephone, an observer may access anyone of the 10 lines, monitor the conversation and, if desired, enter the conversation and converse with the parties on the line. The system is compatible with central office, PABX, Centrex or key system lines or stations.

CONTENTS:

1. General	1
2. Design Features	1
3. Operation.....	3
4. Installation	3
5. Maintenance	4
6. Safety Notes	4
7. Specifications	4
8. Ordering Information	4
9. FCC Requirements	6
10. DOC Requirements	6

2. DESIGN FEATURES

- 2.01 **Talk Assist Option** allows an observer to enter the conversation on the line being monitored. The talk assist feature is easily accessed by simply pressing the asterisk (*) button on the observer's telephone. A TONE DIALING TELEPHONE IS REQUIRED.
- 2.02 **10 Line Capacity** through a key system telephone or a single-line telephone designated as the observer's telephone. When a key system telephone is used, one pick-up key is dedicated for call monitoring. When a single-line telephone is used, the station is dedicated for call monitoring purposes only. Figure 1 and 2.
- 2.03 **Central Office/Trunk Ports** may also be used to access the CM-10. By restricting access to that particular trunk, only designated stations will be allowed to monitor. Figure 2.
- 2.04 **Tone Alert Option** is available to notify users that the line is being monitored.
- 2.05 **Silent Monitoring Option** the CM-10 does not impair transmission over the line or station being monitored, or interfere with the operation of the lines in any manner. No noise is induced onto the monitored lines upon activation or release unless the tone alert option is enabled.
- 2.06 **Volume Control** adjustment is provided to allow for increasing or decreasing the level heard over lines or stations being monitored.
- 2.07 **Easy Mounting** in an apparatus cabinet, a relay rack or on a backboard.

TYPICAL APPLICATION CONFIGURATIONS

A. Dedicated Station Access

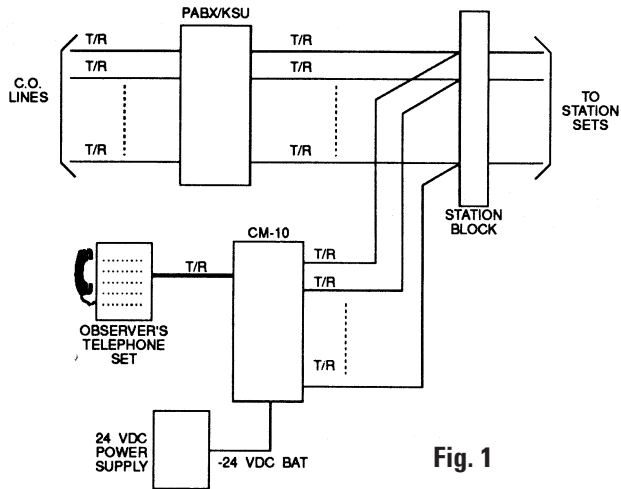

Fig. 1

B. PBX/KSU Station Level Access

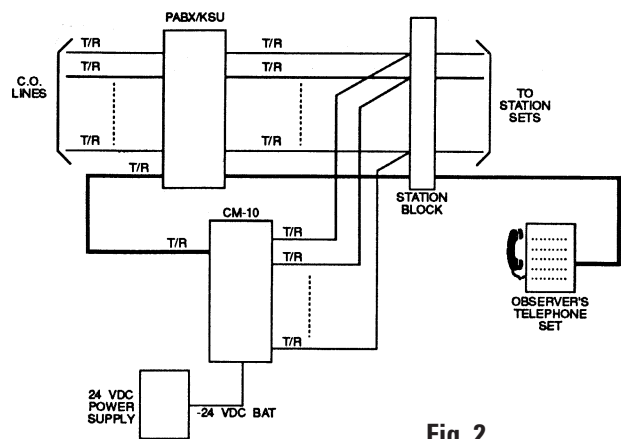

Fig. 2

Condensed Functional Schematic of CM-10

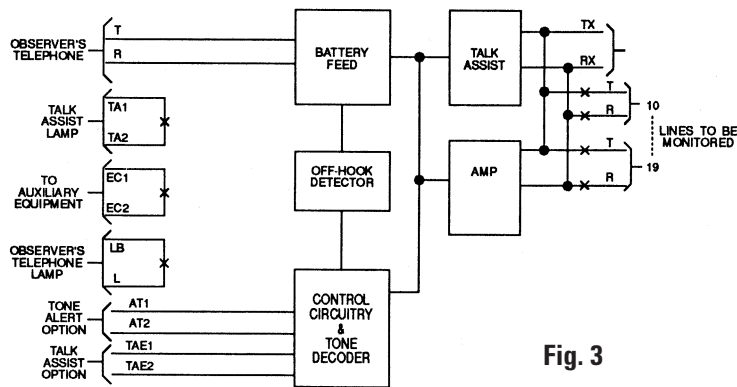

Fig. 3

CM-10 Connections

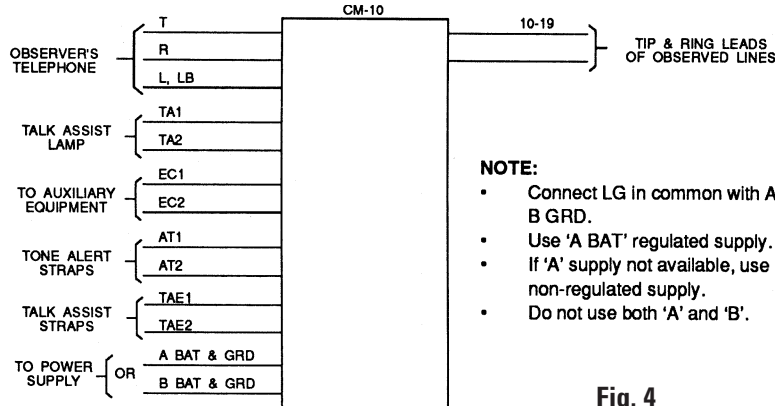

Fig. 4

3. OPERATION

3.01 Lines or stations to be monitored are accessed by dialling numbers 10 through 19. From a single-line observer's telephone, lines are accessed by simply lifting the receiver and dialling the assigned code. From a key system observer's telephone, lines are accessed by pressing the pick-up key dedicated to call monitoring, lifting the handset and dialling the assigned code. On a PBX, the access code programmed for the observing trunk is dialled, then the assigned code.

Nothing will be heard by the parties on the line being monitored. However, if the tone alert option is enabled, upon accessing a line, an audible tone will be heard by both parties. If the lamp lead at the observer's telephone has been connected, the lamp will light to indicate seizure of the CM-10.

3.02 If there is no connection on a line or station accessed for monitoring, nothing will be heard. Another line or station may be successively accessed by pressing the pound (#) button and dialling the next code.

3.03 The observer can access the talk assist feature to enter the conversation on a line being monitored by pressing the asterisk (*) button. When the observer enters the conversation, both parties on the line will hear the observer speak.

Pressing the asterisk (*) again returns the observer to silent monitoring mode. (Toggle).

3.04 The call monitoring/talk assist connection is terminated by pressing the pound (#) button or by returning the handset on-hook.

4. INSTALLATION

4.01 Special installation tools are not required. Mount the CM-10 in an apparatus cabinet, relay rack, or on a wall. Connect the CM-10 plug to a 25-pair connector cable and secure it with the clamps and screws provided. Plug in power supply Dees Model 368 (or tie down as in Figures 4 and 5).

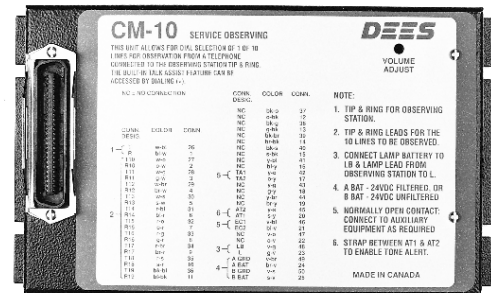

Dees Model CM-10

4.02 Cross connect as shown in Figures 4 and 5.

4.03 The lines or stations to be monitored are accessed by dialling numbers 10 through 19. Connect the tip and ring of the lines or stations to be monitored to the input pairs terminated on the connecting block and designated numbers 10 through 19.

4.04 **To enable tone alert and talk assist options**, refer to Figure 5 for strapping instructions.

4.05 When a lamp is used at the observer's telephone to indicate seizure of a line or station for monitoring, connect the station lamp lead to an L terminal of the connecting block, and lamp supply to the LB terminal. If necessary, derive lamp return ground from the common power supply ground. Refer to Figure 3.

4.06 EC1 and EC2 are extra contacts which are available for control or auxiliary equipment as required. A relay contact closure is provided between EC1 and EC2 when the observer's telephone seizes the CM-10. TA1 and TA2 are extra contacts which are available for control of auxiliary equipment while in the talk assist mode.

- 4.07 Test for proper operation on all lines or stations designated for call monitoring. From the observer's telephone, dial each access code and check to ensure that the access code number and the line or station number agree as assigned. Verify that voice can be heard over each line or station accessed. Check to ensure that all talking paths and power leads are tight.
- 4.08 The CM-10 is equipped with a volume control to allow for adjusting the volume heard over the lines assigned for call monitoring purposes. Adjust the volume to the desired level through the volume control potentiometer.

5. MAINTENANCE

- 5.01 No provisions are made for field adjustment or repair of the CM-10. If the CM-10 does not operate properly, verify connections and check the cable plugs and connectors for proper contact pressure and cleanliness.
- 5.02 If after thoroughly checking cables and connections, the CM-10 still does not operate properly, test the unit by removing the cables and reconnecting them to a substitute CM-10 known to be functional.
- 5.03 The CM-10 is warranted against defects in manufacturing and material. Refer to DEES' Warranty, Service Policy.
- 5.04 For technical assistance on the CM-10, contact DEES.

6. SAFETY NOTES

- 6.01 Never install telephone wiring during a lightning storm.
- 6.02 Never install telephone jacks in wet locations unless the jack is specifically designed for wet locations.
- 6.03 Never touch uninsulated telephone wires or terminals unless the telephone line has been disconnected at the network interface.
- 6.04 Use caution when installing or modifying telephone lines.

7. SPECIFICATIONS

- Operating voltage:-20 to -28 VDC
nominal -24 VDC
- Operating current at -24 VDC:150 mA max.
- Operating temp:.....32° to 122° F
0° to 50° C
- Operating humidity:.....0 to 95%
non-condensing
- Tone dialling parameters:
 - loop length580 ohms
 - interdigital time40 msec
 - input signal level-12 dB to +3 dB
 - bandwidth.....±2%
 - recognition time40 msec
- Tone alert parameters:
 - frequency1,000 Hz
 - tone duration.....0.3 sec
- Relay contact ratings:
 - lamp2 amps at 10 VAC
 - EC1 & EC22 amps at 28 VDC
 - TA1 & TA22 amps at 28 VDC
- Breakdown volts observed lines to ground:
 -1,000 VDC max
- Connections:
 -one A25B or equivalent 25-pair connector cable
- Mounting:
 -apparatus cabinet, relay rack or backboard
- Dimensions:.....9.25" x 5.25" x 1.5" (L x W x D)
- Weight:2.0 lbs

8. ORDERING INFORMATION

- 8.01 Order as follows:
CM-10 SERVICE OBSERVING SYSTEM or
CM-10/PSU SERVICE OBSERVING SYSTEM
e/w 24V Power Supply (Model 368) from your local
supplier or distributor.
- 8.02 For further information, applications engineering or
technical assistance, contact:
Dees Communications Corporation
1-800-654-5604

CM-10 Cable Connections and Connecting Block Assignments

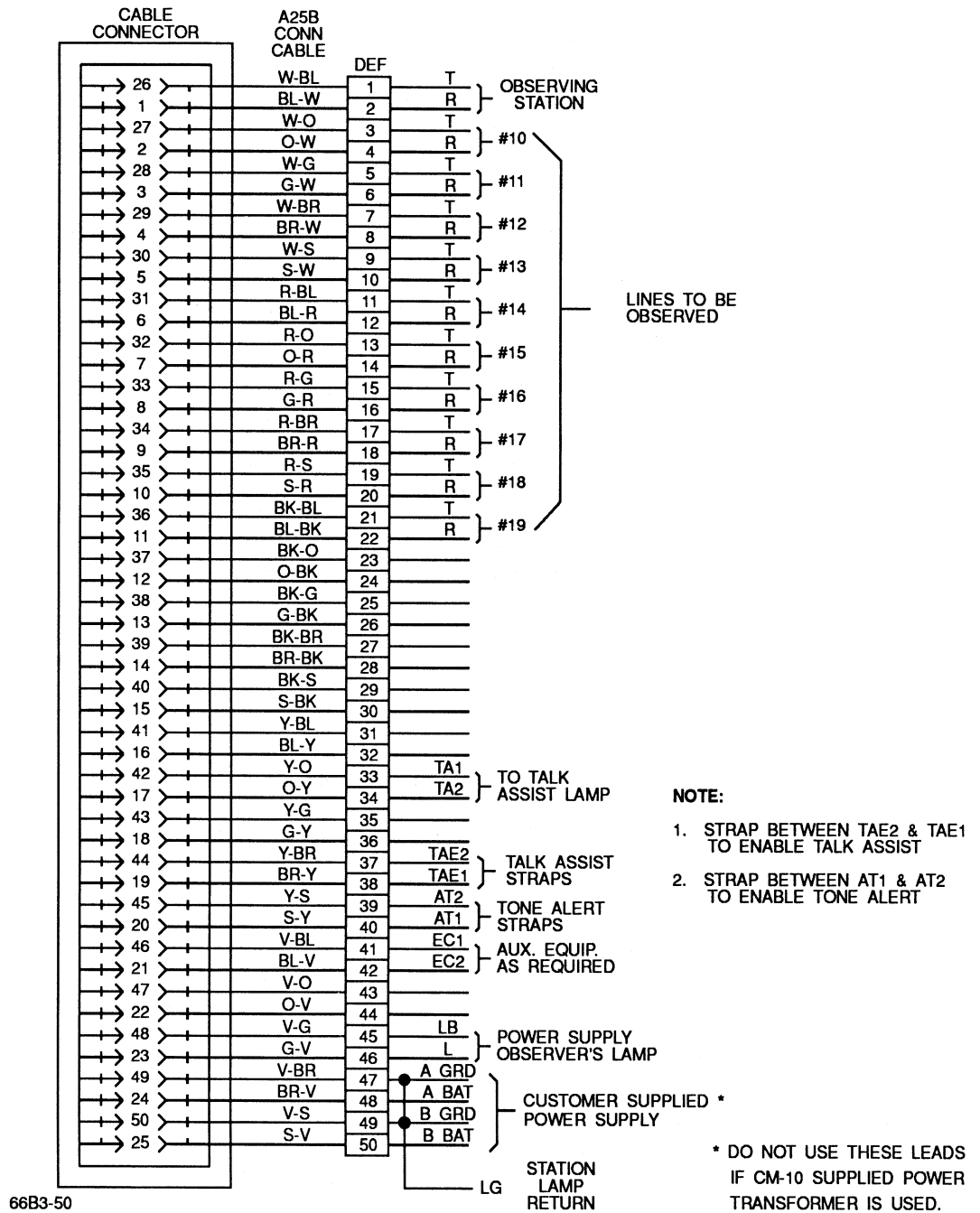

Fig. 5

FCC REQUIREMENTS

TYPE OF SERVICE

Your CM-10 is designed to be used on standard device telephone lines. The CM-10 connects to the telephone line by means of a standard jack called the USOC RJ21X. Connection to telephone company-provided coin service (central office implemented systems) is prohibited. Connection to party lines service is subject to State tariffs.

TELEPHONE COMPANY PROCEDURES

The goal of the telephone company is to provide you with the best service it can. In order to do this, it may occasionally be necessary for them to make changes in their equipment, operations, or procedures. If these changes might affect your service or the operation of your equipment, the telephone company will give you notice, in writing, to allow you to make any changes necessary to maintain uninterrupted service.

If you have any questions about your telephone line, such as how many pieces of equipment you can connect to it, the telephone company will provide this information upon request.

In certain circumstances, it may be necessary for the telephone company to request information from you concerning the equipment which you have connected to your telephone line. Upon request of the telephone company, provide the FCC registration number and the ringer equivalence number (REN) of

the equipment which is connected to your line; both of these items are listed on the equipment label. The sum of all of the REN's on your telephone lines should be less than five in order to assure proper service from the telephone company. In some cases, a sum of five may not be usable on a given line.

IF PROBLEMS ARISE

If any of your telephone equipment is not operating properly, you should immediately remove it from your telephone line, as it may cause harm to the telephone network. If the telephone company notes a problem, they may temporarily discontinue service. When practical, they will notify you in advance of the disconnection. If advance notice is not feasible, you will be given the opportunity to correct the problem and informed of your right to file a complaint with the FCC.

In the event repairs are ever needed on your CM-10, they should be performed by Dees Communications or an authorized representative of Dees Communications. For information contact:

Dees Communications Corporation
4130 - 148th Avenue NE
Redmond, Washington, USA, 98052
Tel: 1-800-654-5604 or 425-869-1963
Fax: 425-869-0717
www.dees.com

DOC REQUIREMENTS

EQUIPMENT ATTACHMENT LIMITATIONS NOTICE

The Canadian Department of Communications label identifies certified equipment. This certification means that the equipment meets certain telecommunications network protective, operational and safety requirements. The Department does not guarantee the equipment will operate to the user's satisfaction.

Before installing this equipment, users should ensure that it is permissible to be connected to the facilities of the local telecommunications company. The equipment must also be installed using an acceptable method of connection. In some cases, the company's inside wiring associated with a single line individual service may be extended by means of a certified connector assembly (telephone extension cord). The customer should be aware that compliance with the above conditions may not prevent degradation of service in some situations.

Repairs to certified equipment should be made by an authorized Canadian maintenance facility designated by the supplier. Any repairs or alterations made by the user to this equipment, or equipment malfunctions, may give the telecommunications company cause to request the user to disconnect the equipment.

Users should ensure for their own protection, that the electrical ground connections of the power utility, telephone lines and internal metallic water pipe system, if present, are connected together. This precaution may be particularly important in rural areas.

Caution: Users should not attempt to make such connections themselves, but should contact the appropriate electric inspection authority or electrician, as appropriate.

This digital apparatus does not exceed the Class A limits for radio noise emissions from digital apparatus set out in the Radio Interference Regulations of the Canadian Department of Communications.

The Load Number (LN) assigned to each terminal device denotes the percentage of the total load to be connected to a telephone loop which is used by the device, to prevent overloading. The termination on a loop may consist of any combination of devices subject only to the requirement that the total of the Load Numbers of all the devices does not exceed 100.