

PAGEPAC PLUS CONTROLLER (V-5323100) AND CONTROLLER WITH POWER SUPPLY (V-5323105)

INTRODUCTION

The PagePac® Plus System consists of the Controller, AmpliCenter, and up to 3 Zone Expansion Units, providing up to 56 paging and/or control zones. The self powered Controller comes with its own power supply, enabling it to control paging and control zones utilizing a paging amplifier other than the AmpliCenter.



Dimensions/Weight

- 16.00"W x 1.80"H x 6.90"D
(40.64cm x 4.57cm x 17.53cm)
2.00 lbs. (0.91 kg)

SPECIFICATIONS

FEATURES

- 8 Zones Paging or Control
- Contact Closure Inputs or Outputs
- Loop Start, Ground Start C O Port, Analog Station or Dry Loop Access (page port with contact closure)
- Controller with Power Supply for Applications with Distributed Amplified Speakers or Amplifiers other than PagePac
- Night Bell
- 7 Alert Tones
- Page Zone Groups
- Flexible Numbering Plan

INSTALLATION

1. Mount the PagePac® Plus Controller and Zone Expansion Units, if any, to either a wall (see Figure 1), cabinet or a rack (below the AmpliCenter or other amplifier) (see Figure 2).

Note: When installing the PagePac Plus Controller, leave at least four inches of space above and below for proper ventilation.

Install the paging equipment in a ventilated room where there is easy access to speaker cabling (preferably in the telephone equipment room).

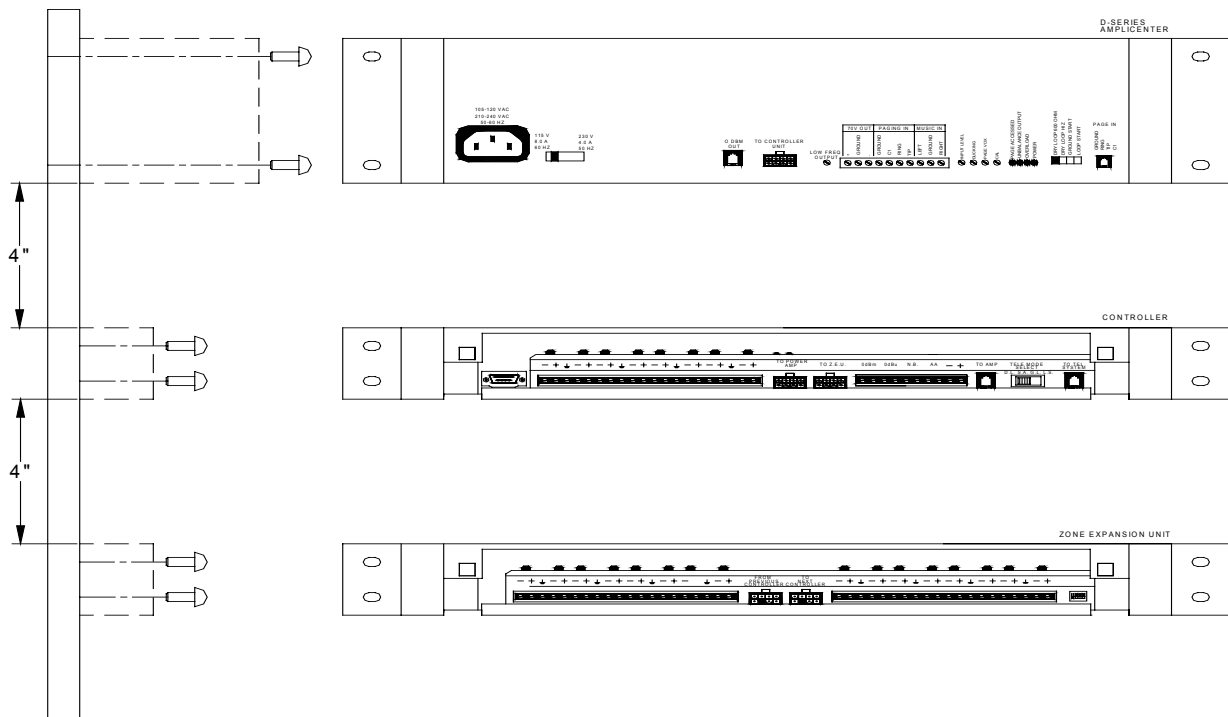

Figure 1. Wall Mounted Hardware

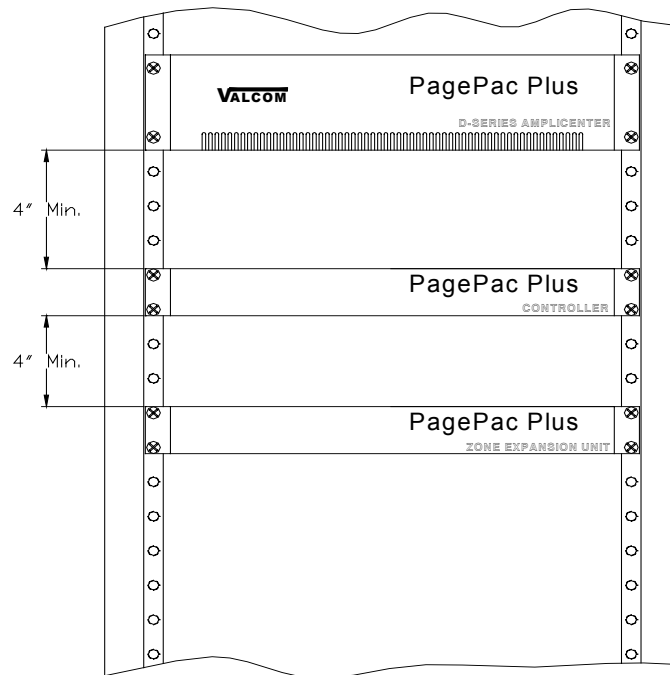
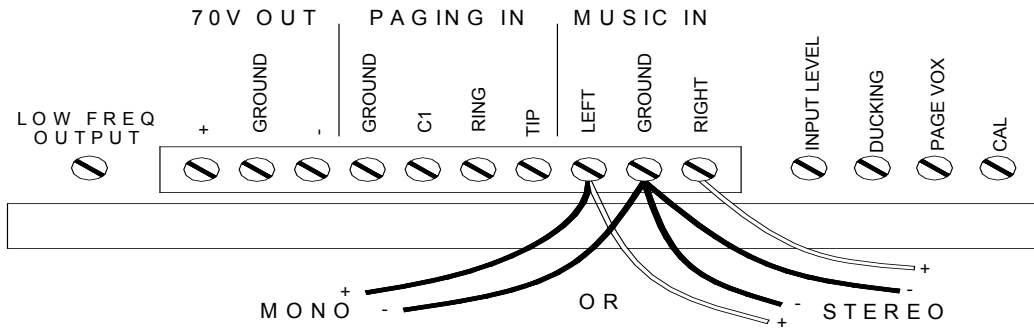

Figure 2. Rack mounted Hardware

2. Connect background music input wires to Left and Right terminals if stereo or Left and Ground if not.
See Figure 3

Note: The optional audio source can be a CD or tape player, AM, FM, or commercial radio, or other audio source.

If more than one AmpliCenter is used in the paging system, each one can be connected to the same music or audio source, or different audio sources, if desired.



3. Plug modular cord into connectors “To Amp” on Controller and “Page In” on AmpliCenter (see Figure 4).

Note: If an amplifier other than the AmpliCenter is used, refer to page 10, Figure 16. There you will find wiring diagrams and notes.

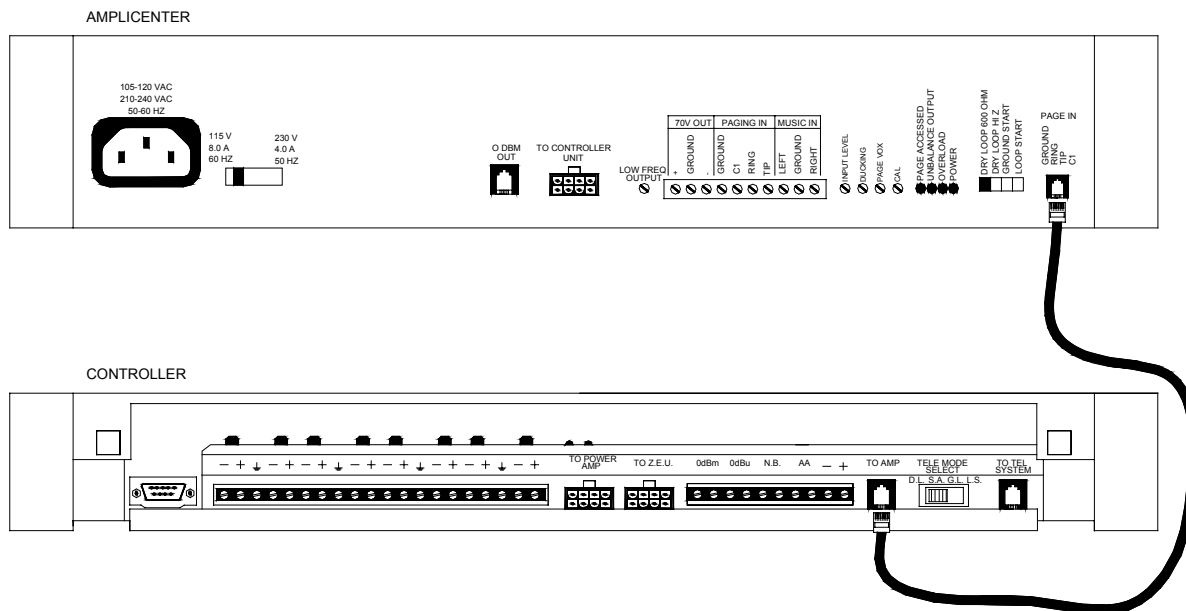

Figure 4. Page In Connection from Controller to AmpliCenter

4. Connect 8-pin Molex connector from AmpliCenter to Controller (see Figure 5).

Note: Connectors can only go in one way. DO NOT force in.

If you are using another type of amplifier, refer to page 10 Figure 16.

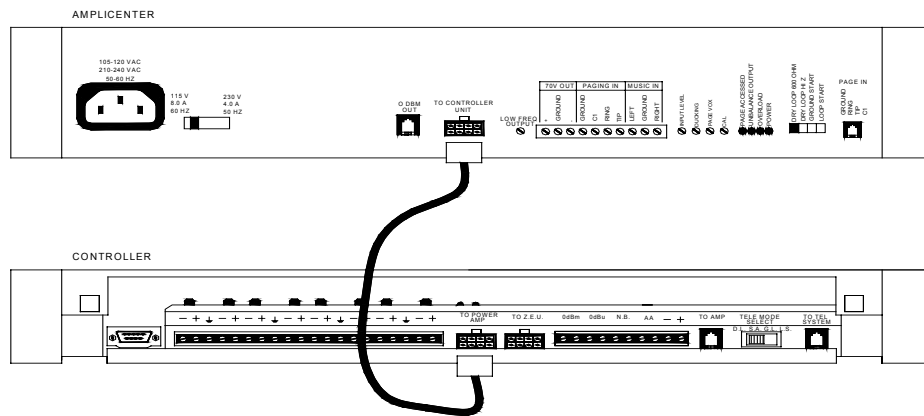

Figure 5. 8-pin Molex Connector from AmpliCenter to Controller

CAUTION

Damage to Controller will occur if the Molex connector (from AmpliCenter) is plugged into the right connector (This goes from Controller to Zone Expansion Unit).

1. Set the AmpliCenter Telephone Mode Selection Switch to Dry Loop 600 Ohms (Far left setting). see Figure 6.

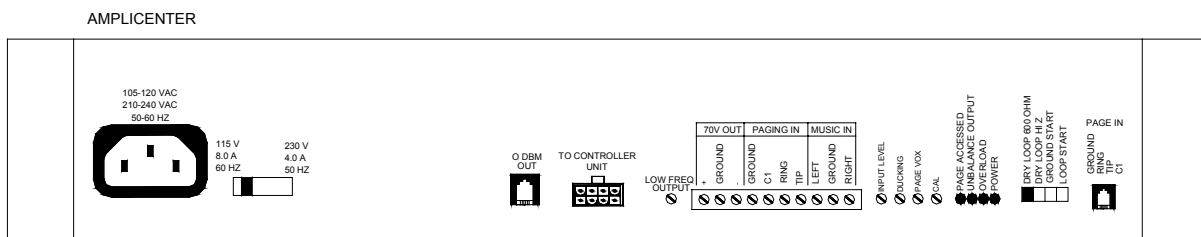

Figure 6. AmpliCenter Mode Switch Setting

2. Connect 8-pin Molex from Controller to Zone Expansion Unit(s), if used. See Figure 7.
Note: Up to 3 Zone Expansion Units can be used, providing up to 56 paging and/or control zones.

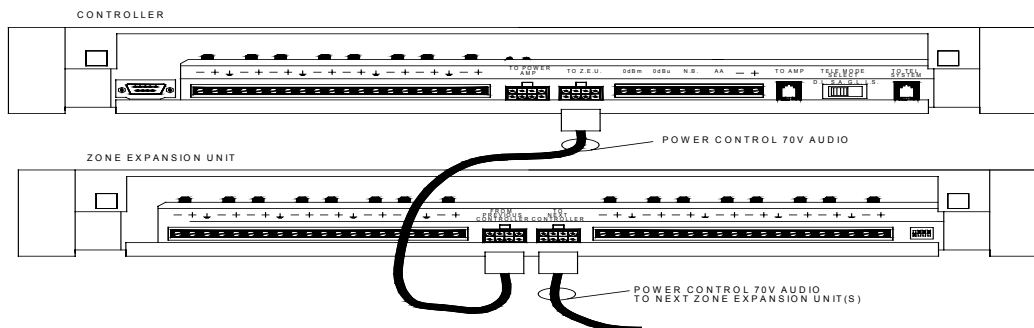

Figure 7. 8-pin Molex Connector from Controller to Zone Expansion Unit(s)

3. Set DIP switches on each Zone Expansion Unit, if any. See Figure 8.

Note: These DIP switches must be set correctly in order for the Controller to recognize the additional zones.

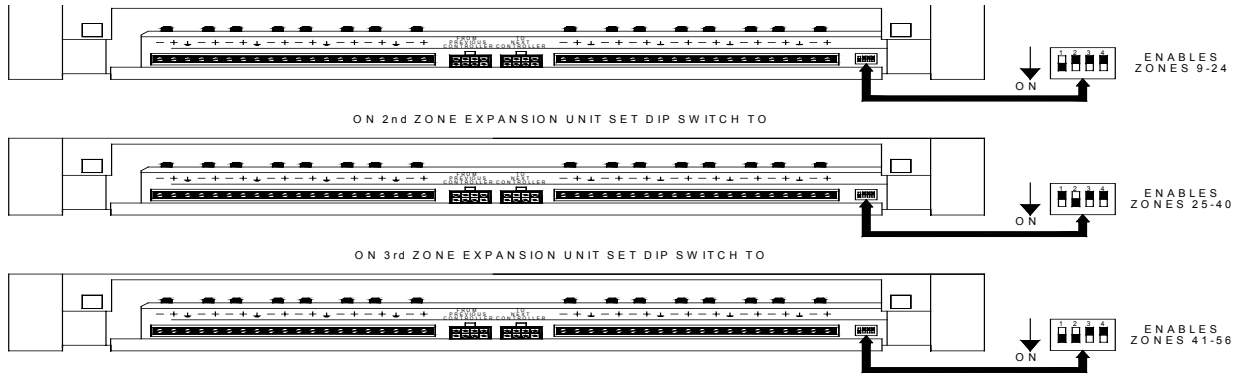

Figure 8. Setting Zone Expansion Unit DIP Switches

4. Using a small standard screwdriver, make the following adjustments:

- A. Adjust the Low Frequency Cut Off control to center position. This control cuts out the low frequency bass so that horns and small speakers are not over-driven and distorted by excessive bass energy. Cut-off frequency is continuously adjustable from 50Hz (full CCW rotation) to 400 Hz (full CW rotation). See Figure 9.
- B. Adjust Music Input level to the center position. Clockwise rotation will increase the level. Listen and set to a comfortable level. (Make sure the music input is not too high check for the overload light on amp).
- C. Adjust Music Ducking level to the fully counterclockwise position. This feature allows music to continue to be heard during a page, but at a reduced level. The range is less than -40dB (full CCW) to -6dB (full CW). If music is not connected, set to full CCW.
- D. Adjust the Page VOX (voiceactivated) sensitivity to the fully counterclockwise position.
- E. Adjust page call to increase page volume or to lower page levels if overload light is on.

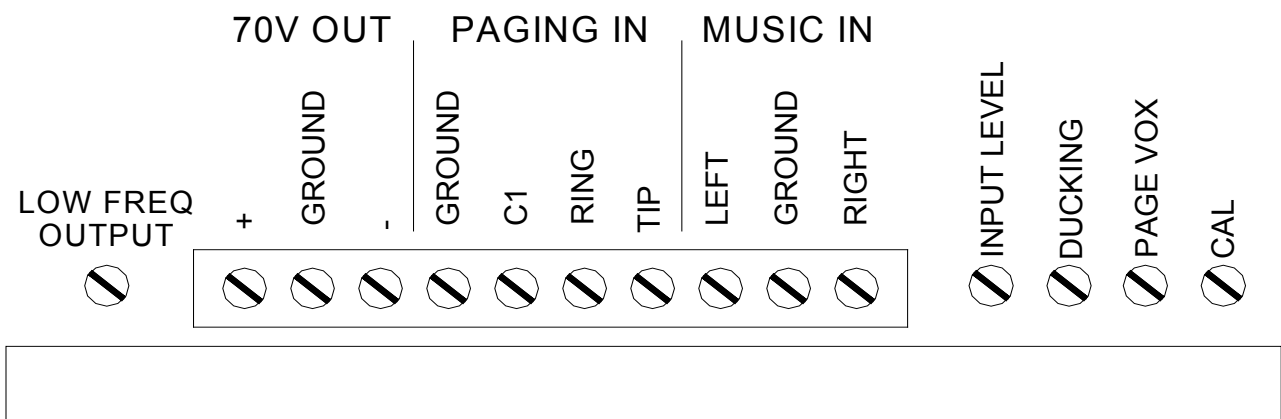

Figure 9. Sound Level Adjustments on AmpliCenter

5. Set Telephone Mode switch on Controller to match host telephone system interface port type.

See Figure 10.

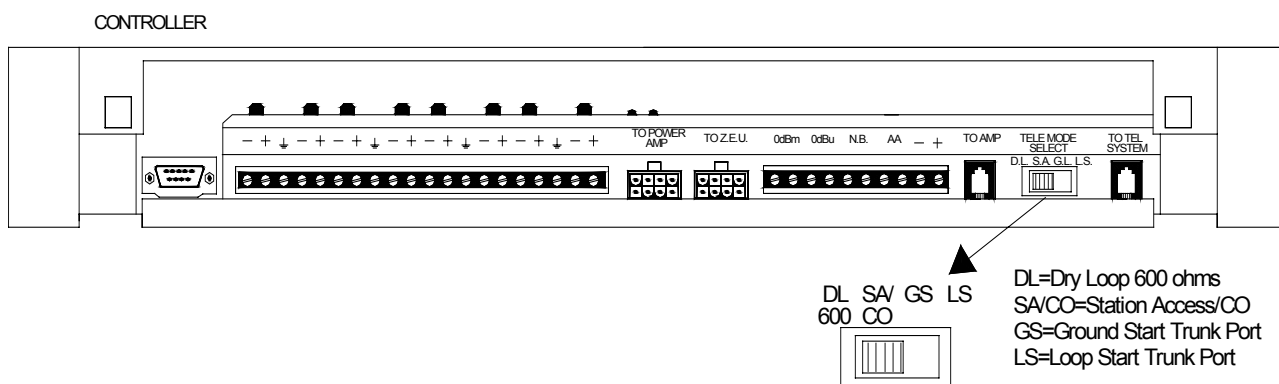

Figure 10. Setting Controller Telephone Mode Switch

6. Connect cable from host telephone system to Controller Page Input. See Figure 11.

Note: Depending on the type of host telephone system interface port, the connection may differ slightly from the illustration to the right. A direct 4-conductor cord from the Controller to the telephone system can also be used, bypassing the connector block.

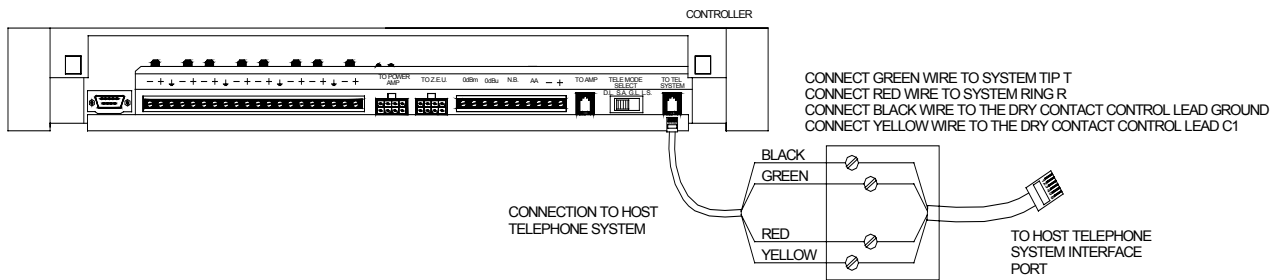

Figure 11. Connecting Host Telephone System to Controller

7. Connect two wires from the night bell analog station port on the host telephone system to Controller night bell (N.B.) input. See Figure 12. (Analog station port needs to provide 90 VAC ring voltage)

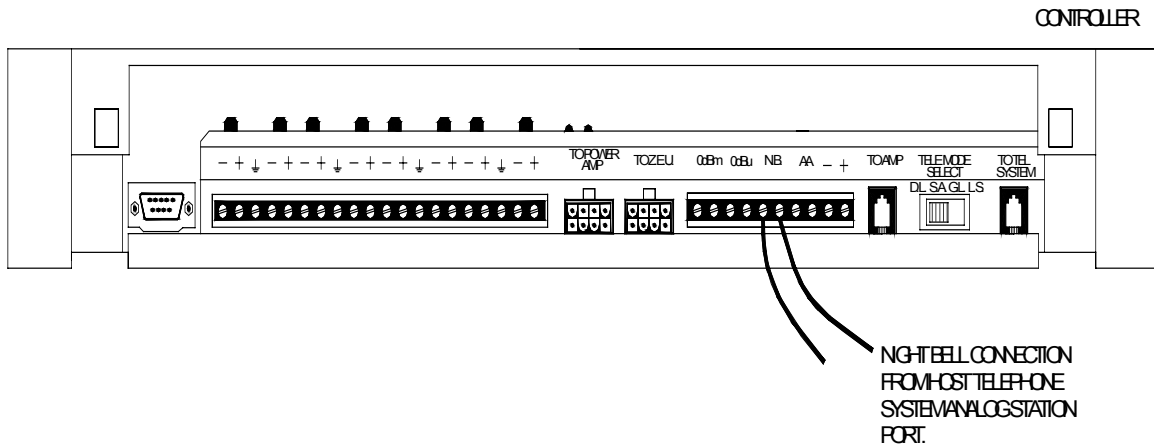

Figure 12. Night Bell Connection to Controller

8. Set the Zone Option switches on the Controller and Zone Expansion Units, if any.

Note: For each zone used, no matter what its function, this switch needs to be set to one of three settings for proper zone operation.

The Controller has eight switches for zones 1-8. Each subsequent Zone Expansion Unit has switches for zones 9-24, 25-40, and 41-56.

TYPICAL CONNECTIONS FOR ZONE CONTROLLER

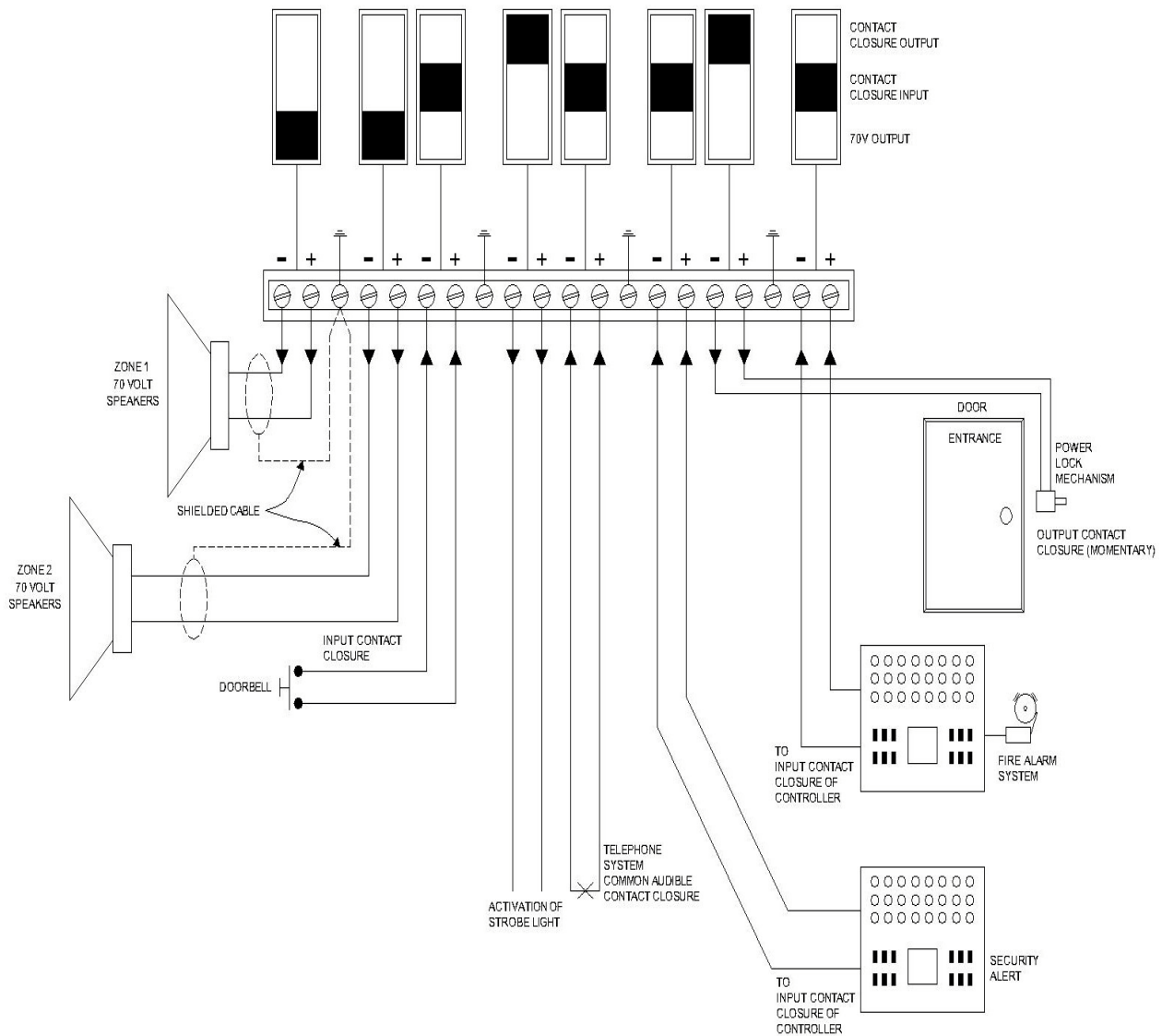

Figure 15. 70 volt Speaker and Contact Closure Zone Wiring to Controller

3. Test speaker wiring for short circuits.

Measure the resistance of each home run wiring with an ohmmeter. Any pair indicating a value of less than 15 Ohms must be rechecked for possible shorted wiring or speakers. Correct any problems and retest.

4. Make zone connections to Controller and any Zone Expansion Units. See Figure 15.

The zone connectors on the Controller and Zone Expansion Units can accommodate up to two 22 AWG wires or four 24 AWG wires per zone output.

Note: DO NOT over tighten zone connector screws.

Check zone option switch setting with Zone Map and Zone Configuration Tables as you connect each zone (A 70V audio output setting going to other than speakers may damage other equipment).

POWERING UP SYSTEM

With all zones wired and connected to the Controller and Zone Expansion Units (if any), initial testing can begin. Refer to Controls and Indicators, Terminals and Connector. Once initial testing is done, you can begin to program the Controller with the features for each zone.

1. Plug the power cord into the AC input connector on the AmpliCenter. The following should happen:
 - A. The green Power LED on the AmpliCenter will turn on and stay on.
 - B. The green Page Access LED on the AmpliCenter also turns on, but will go out after a few seconds.
 - C. On the Controller, verify that the green Phone System Enabled LED is off, and that the yellow Attendant Access Enabled LED is off.
 - D. If background music is connected, adjust the Music In Input Level control on the AmpliCenter(s) for an acceptable level.

NOTE: If an amplifier other than the AmpliCenter is used, make sure it is powered up and verify the Controller LEDs.

2. Make an All Zone test page. Readjust sound levels by adjusting speaker tap settings, if required.
 - A. Readjust Music Input level to the desired loudness relative to paging loudness.
 - B. Some loudspeaker taps may have to be re-adjusted to get even coverage at all Locations. Be sure that the final speaker tap setting totals do not exceed the power Rating of the Amplicenter.
3. Begin programming the Controller (refer to Programming Section).
locations.

SELF-POWERED CONTROLLER CONNECTIONS

The wiring diagrams in Figures 16 through 18 illustrate the connection of the Self-Powered Controller with other amplifiers. In this way, most features associated with the Controller can be utilized with amplifiers other than the AmpliCenter. Refer to Tables 1 and 2 for gain and sensitivity settings.

CONTROLLER WITH POWER SUPPLY TO GENERIC AMPLIFIER

To install the Controller to a Generic Amplifier (see Page 10, Figure 16):

1. Connect 0dBu or 0dBm output to amplifier audio input.

Note: Refer to Table 1 for controller audio output levels and volume control settings.

2. Connect Amplifier Audio Output (70.7V) to Amplified Audio Input on Controller.
3. Adjust Controller volume control (see Table 1).
4. If required, connect control input to amplifier from Controller zone set to “output contact closure program for system HS (program 70).
5. Connect background music if needed to music input.
6. Connect host telephone system to Controller.
7. Plug power pack connector into Controller.

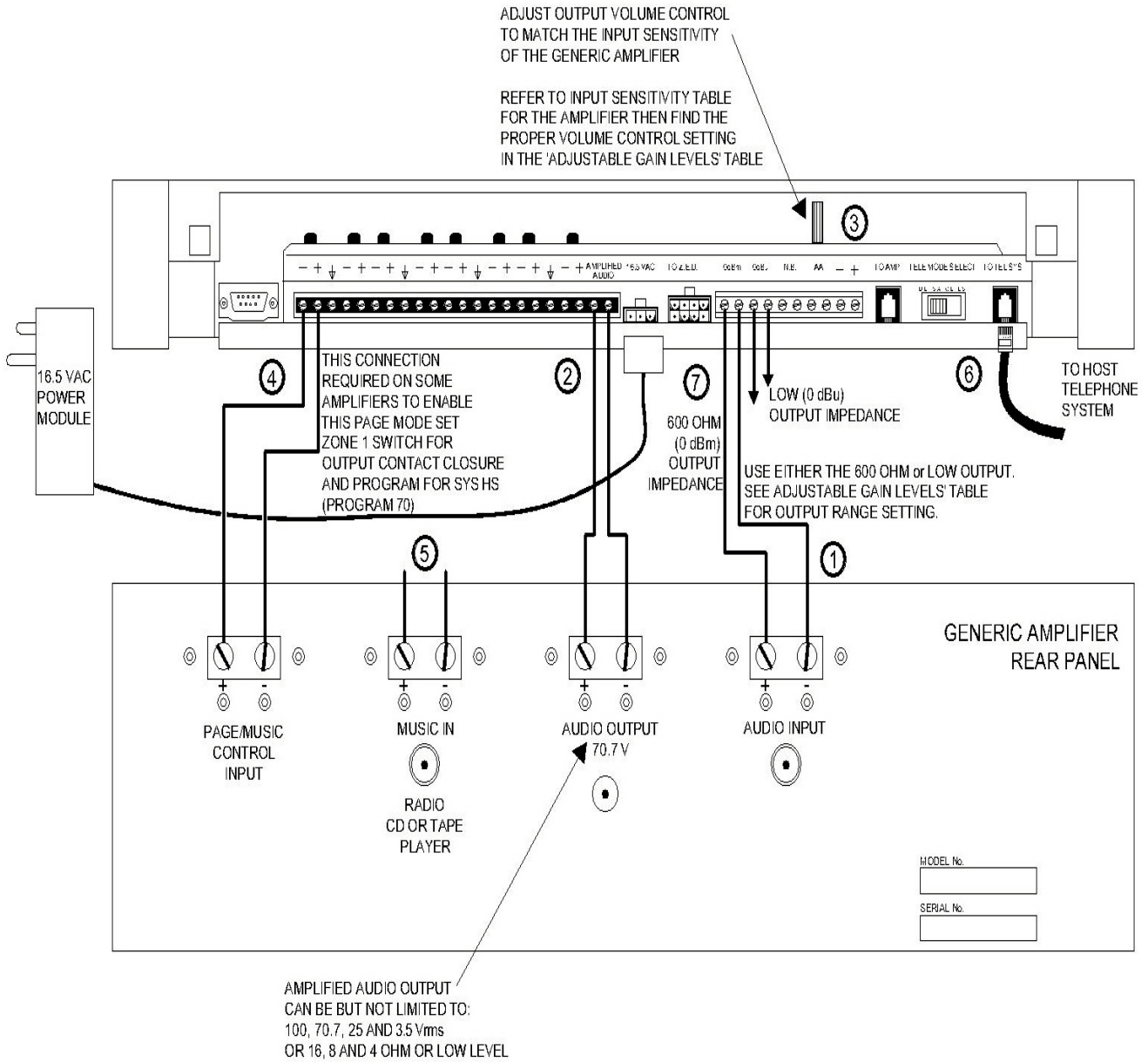

Figure 16. Connection of the Self-Powered Controller to Generic Amplifiers

Table 1. Controller Adjustable Output Level

Controller Volume Control Setting	600 Ohm Impedance Output	Low Impedance Output
Full Counter Clockwise	- 12dBm (195mVrms)	- 6dBu (388mVrms)
Full Clockwise	0dBm (.775Vrms)	+ 6dBu (1.50Vrms)

Note: The generic amplifiers input must be dry, no battery or voltage can be present.

CONTROLLER WITH POWER SUPPLY TO AMPLIFIED SPEAKERS

To install a Controller to Amplified Speakers (see Figure 17):

1. Connect 0dBu output of Controller to Amplified Audio input of Controller.
2. Adjust Controller volume control to mid point.
3. Connect amplified speakers audio input to each zone connector.
4. Set zone option switches to Amplified Audio Output.
5. Connect host telephone system to Controller.
6. Plug Power Pack connector into Controller.

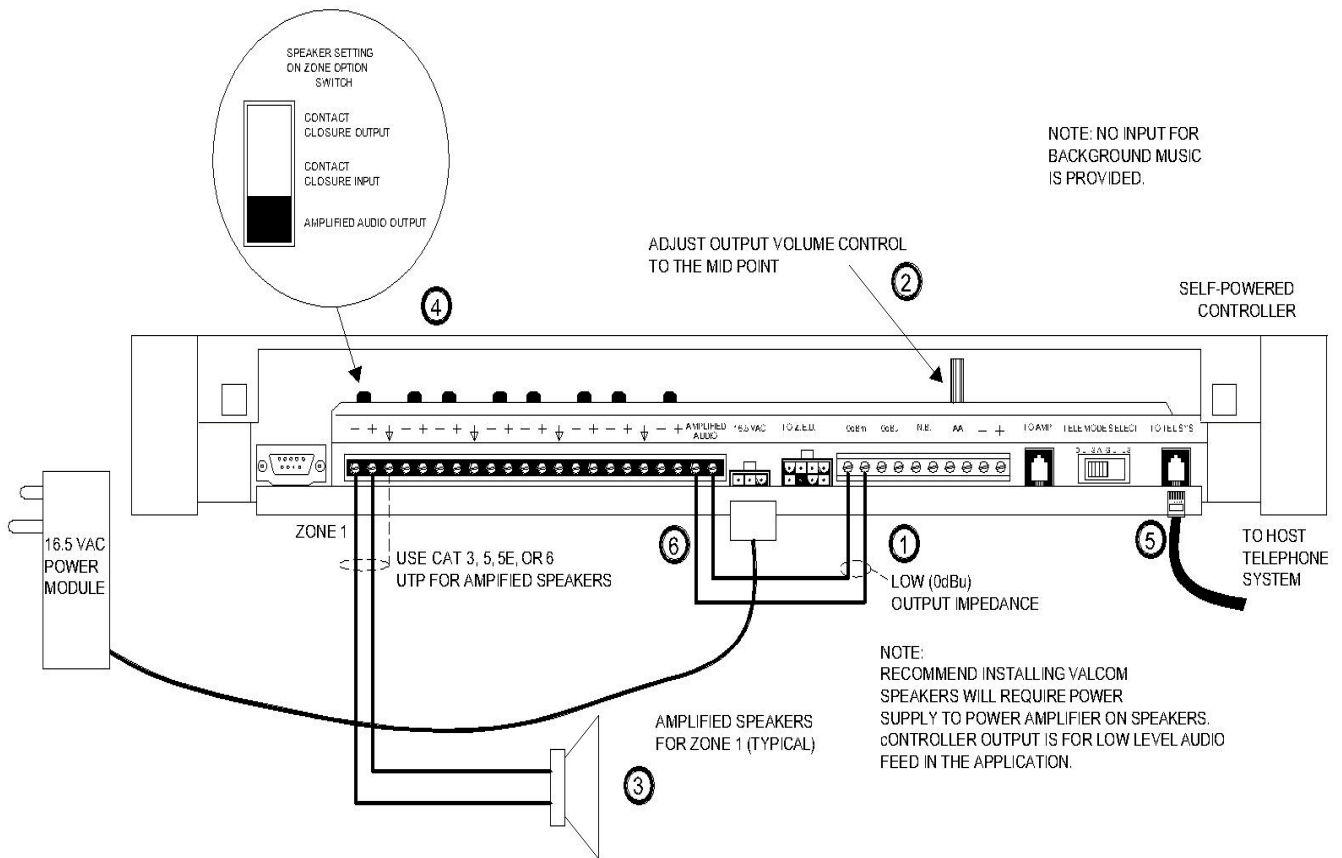

Figure 17. Self-Powered Controller Driving Amplified Speakers

CONTROLLER WITH POWER SUPPLY TO D-SERIES AMPLICENTER

To install a Controller to a D-Series AmpliCenter (see Figure 18):

1. Connect 6-conductor cord from Controller (To Amp) to AmpliCenter Page Input.
2. Connect 70V audio out from AmpliCenter to Amplified Audio, input of controller.
3. Connect host telephone system input to Controller.
4. Connect background music if needed to music input, of AmpliCenter.
5. Plug power pack connector into Controller.

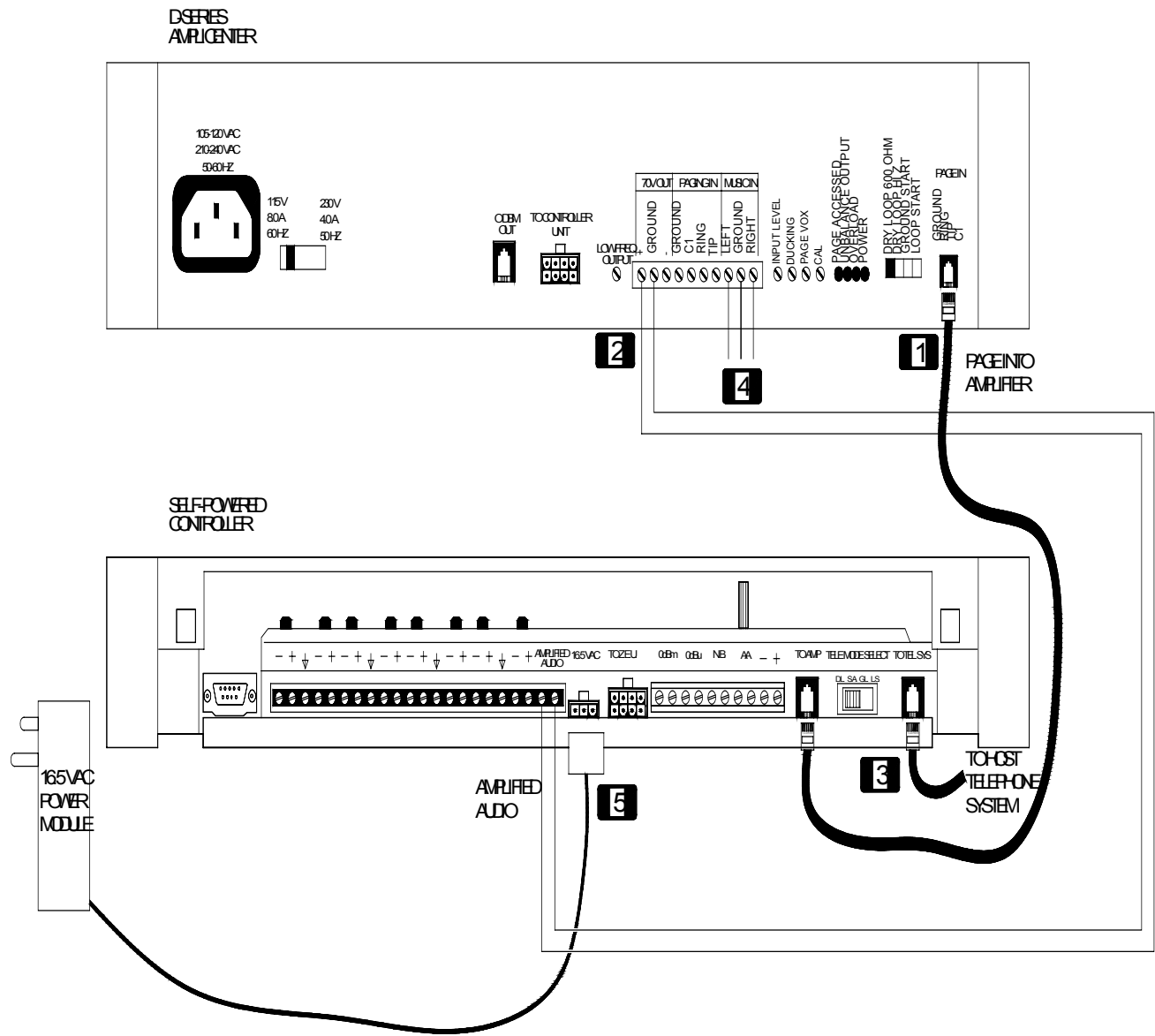

Figure 18. Self-Powered Controller Connected to the PagePac D-Series AmpliCenter

PROGRAMMING THE CONTROLLER

The Controller is programmed to enable each zone to have different zone features, if required. There are two ways to do the programming. One is via the RS-232 serial port on the Controller which is connected to an IBM compatible (DOS) PC using the optional programming software. An advantage of using a PC to configure the Controller is that screens can be viewed on the monitor to aid in selecting the zones for various options. A re-programming of the entire system can be done before downloading the configuration to the controller, saving down time. Furthermore, the old configuration can be saved and used again.

The other method works via the telephone access port (like calling to make a page), which accepts only touchtone telephone keypad inputs (DTMF) tones. The Controller has the ability to retain all programming options in non-volatile EEPROM memory or as a .CFG (configuration) file on a personal computer.

PROGRAMMING STEPS



CAUTION

The Zone Option switches must be set before the system is powered up, and therefore before programming the system.

The Zone Option switches on the rear of the Controller and Zone Expansion units must be set to match the zone option selected for programming. The slide switch for each zone must be manually set to Contact Closure (to switch on/off a device, such as a door security lock, remote amplifier, etc.), Input Contact Closure, or Audio Output, depending on the mode selected for each zone.

IMPORTANT! It is recommended that the paging zone decisions be made and filled in on the Zone Map and Configuration Tables, located on pages 25-29 prior to setting zone option switches and programming.

* * ENTER PROGRAMMING MODE

1. From any DTMF telephone in the system, dial the paging access extension.
2. Dial the Connect Password (if optioned).
You will hear the paging system dial tone.
3. Dial * *

Note: you will hear conformation tone. Now programming may begin.

1 0 RESET TO FACTORY DEFAULTS

1. Dial 1 0
You will hear two beeps from the Controller.
2. Dial 2 5 3 2 7
After a long pause, you will hear three beeps from the Controller. The controller is now set to factory default conditions.
3. Program the system options (refer to the following paragraphs).
You may exit the programming mode by dialing #.

2 0 DEFINE LENGTH OF ALIAS NUMBERS

This system option allows you to set the length (3 or 4 digits) of the ALIAS number field. The default is 2 digits. If you wish to assign ALIAS numbers to the paging zones, you must set the length parameter. The ALIAS number is the dialing extension for the zone. If no ALIAS numbers are used, the Physical Zone Code is the dialing extension for a zone.

Note: This MUST be done before “Zone Map Option – Assigning ALIAS Numbers,” later in this section.

1. Dial 20 to select this option.
Hear a DOUBLE beep.
Press 3 or 4 to set length of ALIAS numbers (number of digits dialed to reach paging zone).
Hear TRIPLE beeps.
2. To verify the setting, dial 2 1 and repeat step 2 above.

2 2 SET SERIAL PORT BIT RATE

The speed (bit rate) of the controller's RS-232 serial port can be set to the rate of the computer monitor or visual display. Default is 9600 bps. The bit rate may be changed at any time, but the Controller must be reset (power off then on again) in order to take effect. (This is the only program change requiring the Controller to be reset).

1. Dial 2 2 to select this option
Hear a DOUBLE beep.
2. Dial a code to select the Serial Port Bit Rate

- 0 to select 300 bps
- 1 to select 1200 bps
- 2 to select 2400 bps
- 3 to select 4800 bps
- 4 to select 9600 bps
- 5 to select 14400 bps
- 6 to select 19200 bps

Hear TRIPLE beeps.

3. To verify the status of this option, dial **2 3** and repeat step 2 above.

2 4 INHIBIT DIAL TONE DETECT

Supervision of the Station/Centrex Access mode is accomplished in 3 ways, by monitoring the loop current and the audio signal (including dial tone), and a forced disconnect timer. This option (only applicable in the station access mode) enables you to defeat the dial tone detect function in order to send a tone via the Telephone Interface to the output.

1. Dial 2 4 to select this option.
Hear a DOUBLE beep.
2. Dial 0 to Enable, or 1 to Inhibit.
Hear TRIPLE beeps.
3. To verify the condition (OFF/ON) of the Dial Tone Detect option, dial **2 5** and repeat step 2 above.

3 0 SET CONNECT PASSWORD

This feature will not become active until the first time you enter a password, via the programming mode. The factory default is NO password. The Connect password operates as a security block into the paging system, restricting paging access to authorized users.

Note: You may want to use a short Connect password (2 or 3 digits only) for ease of use.

1. Dial 3 0 to select this option.

Hear a DOUBLE beep.

2. Enter the Password you wish to use (up to 6 digits). If the password has fewer than 6 digits, enter the # to terminate the string.

Note: For example, 123456 is a valid password entry. 123# is also a valid password entry, resulting in the password 123.

If you already have entered a password and want to remove it (to have NO password), just enter the # alone. Hear TRIPLE beeps.

To verify that the new Connect password has been established, dial **3 1** and repeat step 2 above.

3 2 SET PROGRAMMING PASSWORD

Establishing a Programming password will restrict access to the programming mode of the PagePac Plus paging system. It is recommended that access to programming be restricted to the System Administrator, Telecommunications Manager, or other selected users.

Note: Your Connect and Programming passwords should not be the same. If this feature is active and the system has been accessed via the telephone interface, then after the first digit of your Programming password is pressed, the dial tone will stop and will not be returned until the correct password is entered or until the user hangs up and re-enters the system.

This feature will become active once any programming password has been entered via the programming mode. You are not required to establish such a password. The factory set default programming password is * *.

1. Dial 3 2 to select this option. Hear a DOUBLE beep.
2. Enter the Password you wish to use (up to 6 digits). If the password has fewer than 6 digits, enter the # to terminate the string.

NOTE: For example, 234567 is a valid password entry. 234# is also a valid password entry, resulting in the password 234.

If you already have entered a password and now want to remove it (to have NO password), just enter the # alone. Hear TRIPLE beeps.

3. To verify that the new Programming password has been established, dial **3 3** and repeat step 2 above.

Forgot the Password? If either or both the connect password and programming password are forgotten, it will be necessary to call the Help line (refer to page ii) for instructions how to erase the two passwords and be able to enter new ones.

4 0 TURN CONFIRMATION TONE ON/OFF

When the option is ON, a tone will be sent to the telephone interface after a zone has been selected and before a page can be made. The default setting is ON.

1. Dial 4 0 to select this option. Hear a DOUBLE beep.
2. Dial 0 to turn OFF, or 1 to turn ON. Hear TRIPLE beeps.
3. To verify the Confirmation Tone condition (OFF or ON), dial **4 1** and repeat step 2 above.

4 2 TURN PRE-ANNOUNCEMENT TONE ON/OFF

This tone is very similar to the initial talk-back warning tone, in the sense that it is sent to a zone when the zone is accessed. This tone will be sent out to both speakers in the zone selected and to the telephone interface.

After this tone is sent, you may begin your page message. Default is ON.

1. Dial 4 2 to select this option. Hear a DOUBLE beep.
2. Dial 0 to turn OFF, or 1 to turn ON. Hear TRIPLE beeps.
3. To verify the Pre- Announcement Tone condition (OFF or ON), dial **4 3** and repeat step 2 above.

4 4 SET TALKBACK WARNING TONE

This tone is intended to alert a person that their conversation is being monitored through the paging system loudspeaker. If Talkback is optioned for YES, then the choices will be Initial only, Initial and 30 Second Repeat or Off. The default setting for this parameter is Initial and 30 Second Repeat.

1. Dial **4 4** to select this option. Hear a DOUBLE beep.
2. Dial 0 to turn OFF, 1 to select INITIAL tone only, or 2 to select Initial and 30 Second repeat. Hear TRIPLE beeps.
3. To verify the condition of the Talkback Warning Tone, dial **4 5** and repeat step 2 above.

5 0 SET VOX DISCONNECT TIMING

The system will hang up on a page if no audio is detected for the programmed amount of time. The default time is 30 seconds, but can be varied from 10 seconds to 60 seconds, in 10 second increments, or can be disabled completely.

1. Dial **5 0** to select this option. Hear a DOUBLE beep.
2. Dial the code to select a duration for the VOX Disconnect Timing:

0	to turn OFF		
1	to select 10 seconds	4	to select 40 seconds
2	to select 20 seconds	5	to select 50 seconds
3	to select 30 seconds	6	to select 60 seconds

Hear TRIPLE beeps.
3. To verify the duration of the VOX Disconnect Timing, dial **5 1** and repeat step 2 above.

5 2 ENABLE COMPUTER MONITOR

This option selects a device to be connected to the Controller RS-232 port, a computer monitor for logging of all paging activity or a visual message display. The default setting is Computer Monitor.

By selecting Computer Monitor (the default option), the system is enabled to monitor activity on Attendant Access, Telephone Interface, and Night Bell inputs. This feature requires that a PC computer be connected to the RS-232 port of the Controller. Whenever the input becomes active, ASCII characters will be sent out the RS-232 port (DB9 pin connector) to the computer. The ASCII characters will be inter

cepted by a special software package in the computer that logs the time, date, input zone, type of activity, zone that was paged, and duration of the activity. All such input activity to the paging system can then be viewed (and recorded) on the computer.

By selecting Display, the monitoring activity described above enables commands to be sent to a visual message display where preprogrammed messages are displayed.

1. Dial **5 2** to select this option.
Hear a DOUBLE beep.
2. Dial the **0** to select Computer Monitor, or **1** to select Visual Display
Hear TRIPLE beeps.
3. To verify the status of this option, dial **5 3** and repeat step 2 above.
If a Computer Monitor or visual message display has been connected and Controller software loaded, you will need to select the types of paging inputs to be displayed or recorded. See next programming option select "Input to Computer Monitor."

5 4 SELECT INPUT TO COMPUTER MONITOR

This option turns ON or OFF the inputs of Attendant Access, Telephone Access, and Night Bell to be recorded and displayed by the Computer Monitor if you have activated it in Program **5 2**. Default is OFF for all three.

You will need to repeat this procedure 3 times in order to reset all three inputs.

1. Dial **5 4** to select this option.
Hear a DOUBLE beep.
2. Dial the code to select an option for one of the three inputs:

0	to turn OFF the Attendant Access.
1	to turn ON the Attendant Access.
2	to turn OFF the Telephone Access.
3	to turn ON the Telephone Access.
4	to turn OFF the Night Bell.
5	to turn ON the Night Bell.

Hear TRIPLE beeps.
3. To verify the status of this option, dial **5 5** and repeat step 2 above.

5 6 SET SUPERVISED TRUNK MODE

If the host telephone system does not have a supervised trunk option this feature does not apply.

Proceed to Program **5 8**.

Note: Once the option has been configured, you should place the Controller Telephone Mode switch to the Ground Start position. Connect the telephone interface to a Loop Start trunk on the host system using a standard two-conductor (not four-conductor) RJ-11 cable.

The Supervised Trunk access mode provides both VOX Disconnect and Forced Disconnect timeouts. When the Controller detects that the it has been off hook for two minutes, it opens the trunk circuit for one second, ending the call. Also, if no voice activity is detected for the period specified by the VOX Disconnect programming option Program **50**(normally 30 seconds), or if the telephone is overridden by a higher priority activity (i.e., attendant access), the call is disconnected.

Note: The Ground Start and Station Access modes are not available when the Controller is configured for Supervised Trunk mode. Supervised Trunk mode must be turned off to re-enable these access modes.

1. Dial **5 6** to select this option
Hear a DOUBLE beep.
2. Press **0** to turn OFF, or **1** to turn ON
Hear TRIPLE beeps.
3. To verify the condition (ON/OFF) of the Supervised Trunk mode, dial **5 7** and repeat step 2 above.

5 8 SPECIFY ZONE MICROPHONE

This option allows you to specify that a zone microphone is attached to the Attendant Access interface. When the Zone Microphone option is enabled (ON), the controller will wait for a zone to be selected from the microphone keypad before it makes a page. When disabled (OFF), the controller reverts to its normal (All Call) operation.

1. Dial 5 8 to select this option
Hear a DOUBLE beep.
2. Dial 0 to turn OFF, or 1 to turn ON
Hear TRIPLE beeps.
3. To verify the condition (OFF/ON) of the Zone Microphone option, dial 5 9 and repeat step 2 above.

GENERAL ZONE AND ZONE GROUP CONFIGURATIONS

General Zone and Zone Group Configurations are options that apply to selected zones or groups, not to the entire system. The steps following Copy Command, describe each option.

1 2 COPY COMMAND

The COPY command can be used to copy the configuration of a zone that has already been optioned, to one or more additional zones. This saves re-entering the same parameters over again, to duplicate the parameters of an existing zone.

1. Dial 1 2 to activate COPY command.
Hear a DOUBLE beep tone.
2. Enter the zone number that you wish to copy from (i.e., 01).
Hear DOUBLE beep tone.
3. Enter the zone number of the beginning of the range of zones you wish to copy to.
Hear a DOUBLE beep tone.
4. Enter the zone number of the END of the zone range to be copied to.
Hear a TRIPLE beep tone.

Note: Program the Controller using the physical zone number.

6 0 ZONE MAP OPTION -- ASSIGNING ALIAS NUMBERS

Note: Before doing this option, you MUST do "Define Length of ALIAS Numbers" (Program 2 0).

Zone Map permits you to assign the dialing code, called the ALIAS zone code, that you will dial to access a particular zone by telephone (i.e., instead of dialing 02 to make a page, you could dial 2202). The factory default is NONE: no ALIAS numbers are pre-programmed. The zones are identified by their 2-digit Physical Zone Codes (01 thru 56 and groups 81-88) as the default condition.

Digit string length for an ALIAS code can be 3 or 4 digits, but all ALIAS codes must have the same number of digits. The * and # digits are not applicable digits for zone ALIAS numbers.

Note: If ALIAS numbers are enabled, you MUST use them for programming from now on. When an ALIAS number for a zone is changed, all the previous zone options for that zone will be transferred to the new zone number.

Refer to your own Zone Map and the Example Zone Map at the end of this programming section.

1. Dial 6 0 to select this option.
Hear a DOUBLE beep.
2. Enter the 2-digit PHYSICAL zone/group code, of the zone or group to give an ALIAS number.
Hear a DOUBLE beep.
3. Enter the ALIAS zone/group number you have chosen.
Hear TRIPLE beeps.
4. To verify the assignment of an ALIAS to a selected zone or group, dial 6 1 and repeat steps 2 and 3 above.

6 2 TYPE OF ZONE: INPUT OR OUTPUT

The choices here are INPUT #1, INPUT #2, and OUTPUT. Be sure the manually selectable Zone Option switch on the rear of the Controller or Zone Expansion Unit is set to match the type of zone selected (input or output). Input #1 would be used for an emergency alert, say a connection to your alarm system. Input #2 would be a lower priority, say a doorbell input.

Note: The INPUT #1 option must only be assigned to physical zones 1 through 8 (on the Controller).

The factory default is OUTPUT (i.e., all zones are output type, by default).

1. Dial **6 2** to select this option.
Hear a DOUBLE beep.
2. Enter the number of the zone or zone group to be optioned. Use ALIAS numbers, if optioned.
Otherwise, use Physical zone/group numbers.
Hear a DOUBLE beep.
3. Press **0** to designate the zone as OUTPUT
Press **1** to designate it as INPUT #1, or
Press **2** to designate it as INPUT #2.
Hear TRIPLE beeps.
4. To verify the zone type assignment, dial **6 3** and repeat steps 2 and 3 above.

SET INPUT PRIORITY ARRANGEMENT

The input priorities are pre-set at the factory. You may only assign a priority level to inputs such as security alarm, or doorbell by assigning them to Input #1 or Input #2, which differ in priority.

Note: These priorities cannot be rearranged. Also, if you select more than one zone to be inputs of the same level (Input 1, for example), such inputs will be handled on a first in, first served basis. See Type of Zone option, under Zone/Group Configurations programming, later in this section.

The default setting is:

- 1 – Attendant Access
- 2 – Input #1
- 3 – Telephone Access
- 4 – Input #2
- 5 – Night Bell
6. Music (always lowest priority).

6 4 SET ZONE GROUPING TO PAGE

This option allows you to select a group of zones to be paged at the same time. The number of zone groups that can be configured is eight; the maximum number of zones per group is 56 zones.

The factory default is NONE (there are no default zone groups).

You will need to repeat this procedure for each zone group you wish to set up.

1. Dial **6 4** to select this option.
Hear a DOUBLE beep.
2. Enter the zone code, of the zone group to be defined (81 thru 88).
Hear a DOUBLE beep.

For example, dial 81 for zone group 81 (Zone group 80 is always All Call). Use ALIAS numbers, if optioned. Otherwise, use Physical zone/group numbers.

3. Enter zone codes of each zone to be included in the group.
Hear a Confirmation Tone for each zone, then dial tone.
4. Press **#** to end the string of zones.
Hear TRIPLE beeps.

For example, 01 (tone), 02 (tone), 13 (tone), 14 (tone), #, indicates zones 1, 2, 13, and 14 are included in this group. Enter the codes consecutively, with no digit or character between them. Use ALIAS numbers, if optioned. Otherwise, use Physical zone/group numbers.

5. To verify the zone group assignment, dial **6 5** and repeat steps 2 and 3 above.

6 6 SET ZONE OR GROUP ZONE TO REMOTE MONITOR

This option selects a zone or zone group for computer monitoring, (logging of paging activity), or for visual message display. The default setting is off (Refer to Program **5 2** and **5 4**).

1. Dial **6 6** to select this option. Hear a DOUBLE beep.
2. Enter zone or zone group number.
3. Dial the code to activate this option:
0 to select OFF

1 to select ON.

Hear TRIPLE beeps.

4. To verify the status of this option, dial 6 7 and repeat step 2 above.

OUTPUT ZONE/GROUP CONFIGURATIONS

These options apply to zones or groups already configured as outputs (see Program 62, Type of Zone). All these parameters can be individually optioned per zone. For a summary of these options, see the Programming Quick Reference Chart at the end of this section.

7 0 SET OUTPUT ZONE TYPE

This option selects the type of output for an individual output zone. The choices here are Audio/Normally Open, Momentary Open, Normally Closed, System Handshake, Toggle, Phantom, and Attendant Access Handshake. The Audio/Normally Open option is the default.

When the System Handshake option is chosen, the closure will energize when a valid Off Hook condition has been detected. The Attendant Access Handshake zone provides an output contact closure when Attendant Access interface is accessed.

Note: System Handshake is a feature required by certain PBX systems: when they access the paging system, they require a return acknowledgment signal – the “handshake” – from the Controller.

A Phantom Zone is an output zone that exists only in software. If a page is made to a Phantom zone, the controller will send a message to an attached monitoring device (if configured) and will issue confirmation tone, but will take no action with respect to the zone's hardware. This allows uninstalled zones to be used to select messages on a visual display.

The Momentary Open, Normally Closed and Toggle options are intended to be used for controlling door striker plates, for instance, to permit a security door to be unlocked. The Momentary Open will stay energized for as long as the zone is selected. The Toggle will stay energized until the zone is selected again and change relay until it is accessed again. Normally Closed will open only when the specific zone is selected. Neither of these modes will respond to an Attendant Access page, an All-Call and/or Zone Grouping page.

Repeat this procedure for each output zone.

1. Dial 7 0 to select this option.

Hear a DOUBLE beep.

2. Enter the output zone number.

Hear a DOUBLE beep.

Note: Use alias numbers, if optioned. Otherwise, use physical zone/group numbers.

3. Enter the code for the type of output you wish to select:

- | | |
|---|---|
| 0 | selects AUDIO/N.O. (Normally Open) |
| 1 | selects Momentary Open |
| 2 | selects N/C (Normally Closed) |
| 3 | selects Sys HS (System Handshake) |
| 4 | selects Toggle |
| 5 | selects Phantom |
| 6 | selects AA Ready (Attendant Access Handshake) |

Hear TRIPLE beeps.

4. To verify the Type of Output assignment, dial 7 1 and repeat steps 2 and 3 above.

7 2 SET PAGE ENABLE

This output zone parameter enables paging for a selected output zone or zone group. The choice for this selection is YES/NO, with the default being YES. Repeat this procedure for each output zone or zone group.

Note: If you make an all-call page and this option is selected NO in either a zone group or individual ones, then an all-call page will be made to all other zones except the ones specified. If the decision is NO for the all-call zone and an all-call page is made, then an error tone will be returned to you.

1. Dial 7 2 to select this option.

Hear a DOUBLE beep.

2. Enter the zone number, of the zone or group you wish to configure.

Hear a DOUBLE beep.

Note: Use ALIAS numbers, if optional. Otherwise, use physical zone/group numbers.

3. Enter 0 for NO (Page Not Enabled) or 1 for YES (Page enabled)

Hear TRIPLE beeps.

To verify the status of Page Enable for a given zone, dial **7 3** and repeat steps 2 and 3 above.

7 4 SET MUSIC ENABLE IF BACKGROUND MUSIC IS USED

This is an individual zone output parameter, that enables background music to be broadcast to a selected output zone (in the absence of a higher priority paging output). The choice is YES/NO, with the default being NO.

Repeat this procedure for each output zone that you wish to have background music.

1. Dial **7 4** to select this option.

Hear a DOUBLE beep.

2. Enter the zone number.

Hear a DOUBLE beep.

Note: Use ALIAS numbers, if optional. Otherwise, use physical zone/group numbers.

3. Enter **0** for NO (Music Not Enabled) or **1** for YES (Music enabled)

Hear TRIPLE beeps.

4. To verify the status of Music Enable for a given zone, dial **7 5** and repeat steps 2 and 3 above.

7 6 SET TALKBACK ENABLE

This is a zone or zone group output parameter that enables talkback capability for a selected output zone or group. The choice is YES/NO, with the default being set to NO.

All speakers in a zone or group will be active 2-way speakers if talkback has been enabled. Repeat this procedure for each output zone or zone group that you wish to have talkback.

1. Dial **7 6** to select this option.

Hear a DOUBLE beep.

2. Enter the zone or zone group number.

Hear a DOUBLE beep.

3. Enter **0** for NO (Not Enabled) or **1** for YES (Enabled)

Hear TRIPLE beeps.

4. To verify the status of Talkback Enable for a given zone, dial **7 7** and repeat steps 2 and 3 above.

Note: Only 2 talkback speakers are recommended per zone.

7 8 SET NIGHT BELL ENABLE

This is an individual zone output parameter. The choice is YES/NO with the default being NO. With this parameter set to YES, night bell will be sent to selected outputs whenever ring voltage is present on the night bell input (from the PBX to the controller).

If a closure is required to trigger the night bell, then a zone will need to be configured as an input to send night bell to designated zones when a closure is present. This is discussed in program 92 and 94, Tone Selection and Tone Routing.

You will need to repeat this procedure for each output zone that you wish to receive the night bell signal.

1. Dial **7 8** to select this option. Hear a DOUBLE beep.

2. Enter the zone or zone group number. Hear a DOUBLE beep.

Note: Use ALIAS numbers, if optional. Otherwise, use physical zone or group numbers.

3. Enter **0** for NO (Not Enabled) or enter **1** for YES (Enabled). Hear TRIPLE beeps.

4. To verify the status of Night Bell Enable for a given zone, dial **7 9** and repeat steps 2 and 3 ABOVE.

9 0 PASS DTMF TO THE OUTPUT

This zone output option enables the Touchtone telephone keypad tones (DTMF) to be passed through the Controller and output to a second controller or other auxiliary device.

The choice is YES/NO, with the default being NO. Operating the unit in the default mode, you may switch from zone to zone (within the same Controller) without hanging up, simply by dialing the zone number of the zone you wish to switch to. The DTMF tones you dial will be muted (not sent out as audio) as soon as they are detected by the controller.

Access to the first zone will be disconnected when the zone switch has been accomplished.

When you have accessed a zone with this parameter set to YES, DTMF will be sent out as un-muted audio but the Controller will not respond to the DTMF tones (and will not switch zones).

This YES option, with DTMF tones enabled to the output, is useful when you have more than one Controller connected in a system. The DTMF tone is passed through the first controller (not triggering a zone change) to the second controller (or other auxiliary device).

You will need to repeat this procedure for each output zone or zone group that you wish to send DTMF tones to the output.

1. Dial **9 0** to select this option.
Hear a DOUBLE beep.
2. Enter the zone or zone group number.
Hear a DOUBLE beep.
3. Enter 0 for NO (Not pass DTMF) or enter **1** for YES (Pass DTMF)
Hear TRIPLE beeps.
4. To verify the status of DTMF Pass for a given zone dial **9 1** and repeat steps 2 and 3 above.

INPUT ZONE/GROUP OPTIONS

These options apply to zones or groups already configured as inputs (see Type of Zone, Program 6 2). These options are summarized in the Programming Quick Reference Chart, at the end of this section.

9 2 TONE SELECTION

If a zone is configured to be an input and is activated, then a tone may be selected to be directed to whatever zone(s) are selected in Tone Routing, Program **9 4**. The tone selections are listed in step 3.

For example, you wish to have a doorbell pushbutton input cause a chime to be heard in certain zones. You have already configured the zone of the doorbell as an input zone. You need to select the tone (chime) you wish to be heard in the output zones, when the doorbell is pressed. This is called Activate Tone via an Input Closure, on the Quick Reference Chart.

The default setting for this option is NONE (not activated).

1. Dial **9 2** to select this option.
Hear a DOUBLE beep.
2. Enter the number of the input zone (i.e., the zone containing the doorbell pushbutton).
Use ALIAS numbers, if optioned. Otherwise, use Physical zone/group numbers.
Hear a DOUBLE beep.
3. Enter the tone option, 0 through 7.

0	None
1	Chime
2	Siren
3	Warble Siren
4	Night Bell
5	Fast Ring
6	Steady Tone
7	Door Bell

Hear TRIPLE beeps.

4. To verify the tone option for a given input zone, dial **9 3** and repeat steps 2 and 3 above.

9 4 SET TONE ROUTING

Whatever zones are selected here will receive the tone selected in the previous option, Tone Selection.

For example, you have optioned an input zone to receive a doorbell pushbutton input. And you have selected a tone (Program **9 2**) to be output when the doorbell input is received. Now you must select the output zone or zone group which will receive the tone.

1. Dial **9 4** to activate Tone Routing.
Hear a DOUBLE beep.
2. Enter the input zone number.
Hear a DOUBLE beep.
3. Enter the output zone or zone group number.
Hear TRIPLE beeps.

4. To verify Tone Routing, dial **9 5** and repeat steps 2 and 3 above.

Note: Use ALIAS numbers, if optioned. Otherwise, use physical zone/group numbers.

9 6 AUDIO SOURCE ENABLE

The primary use for this feature is to allow the paging system to be used for door service. If optioned, whenever a selected zone is active (i.e., the doorbell pushbutton), an audio source (either Telephone Access or Attendant Access) will be routed automatically to a zone (the door speakerphone) selected in Audio Routing, below. The default for this option is NONE.

1. Dial 9 6 to select Audio Source Enable.
Hear a DOUBLE beep.
2. Enter the input zone number.
Hear a DOUBLE beep.

Note: Use ALIAS numbers, if optioned. Otherwise, use physical zone numbers.

3. Enter 0 (NONE), 1 (AA, Attendant Access), or 2 (T/R, Telephone Access) to select the audio source.(or none) to be enabled when this zone is activated.
Hear TRIPLE beeps.
4. To verify your selection, Dial **9 7** and repeat steps 2 and 3, above.

9 8 SET AUDIO ROUTING

If optioned, whenever a selected input zone with "Audio Source Enabled" is active, the audio source (either Telephone Access or Attendant Access) will be routed to the selected zone or group. The default for this parameter is NO ZONES.

Door Service

The primary use for this feature is to allow the paging system to be used for door service. For example, you have optioned the doorbell input zone to enable Telephone Access, and you wish now to select the door speaker to be the output zone for this Telephone Access audio.

The audio path will remain routed for 10 seconds. If the user accesses the controller during the 10 second period, they will automatically be routed to the zone specified in this procedure. If the user accesses the controller after the time expires, the user will receive a dial tone.

Note: If a Connect password has been programmed in the system, you will have to access the paging system and enter the password, before being automatically routed to the zone.

If the doorbell input has a higher priority than the telephone access and is activated while telephone access paging is underway, then you will receive the tone specified in the option Tone Selection, above, and then will be automatically routed to the proper zone.

1. Dial 9 8 to select Audio Routing.
Hear DOUBLE beeps.
2. Enter the input zone or group zone number.
Hear DOUBLE beeps.
3. Enter the output zone / group ALIAS number.
Hear TRIPLE beeps.

Note: Use ALIAS numbers, if optioned, otherwise, use physical zone numbers.

4. To verify your selection, dial 9 9 and repeat steps 2 and 3 above.

PROGRAMMING QUICK REFERENCE TABLE

Table 1. System Configuration Options

Feature	Mode Option/ Verify	Dial	Listen For	Choose Option	Listen For	Default
Reset to Factory Defaults	To Select	10	Double Beep	Enter 25327 to reset. Enter any invalid number string to escape.	Triple Beep	25327 (CLEAR)
Number of Zone Map Digits	To Select To Verify	20 21	Double Beep	Three digit Four digit	Triple Beep	2
Serial Port Bit Rates	To Select To Verify	22 23	Double Beep	0 – 300 bps 1 –1200 bps	Triple Beep	9600 bps

				2 - 2400 bps 3 - 4800 bps 4 - 9600 bps 5 - 14400 bps 6 - 19200 bps		
Dial Tone Detect	To Select To Verify	24 25	Double Beep	0 - Enables 1 - Inhibit	Triple Beep	Enable
Connect Password	To Select To Verify	30 31	Double Beep	Enter Password, enter # to terminate the string.	Triple Beep	None
Programming Password	To Select To Verify	32 33	Double Beep	Enter Password, enter # to terminate the string.	Triple Beep	* *
Confirmation Tone	To Select To Verify	40 41	Double Beep	0 - Off 1 - On	Triple Beep	On
Pre-Announcement Tone	To Select To Verify	42 43	Double Beep	0 - Off 1 - On	Triple Beep	On
Talkback Warning Tones	To Select To Verify	44 45	Double Beep	0 - Off 1 - Initial 2 - Initial in 30 sec.	Triple Beep	Initial and 30 sec.
VOX Timer Disconnect	To Select To Verify	50 51	Double Beep	0 - Off 1 - 10 sec. 2 - 20 sec. 3 - 30 sec. 4 - 40 sec. 5 - 50 sec. 6 - 60 sec.	Triple Beep	30 Sec.
Computer Monitor	To Select To Verify	52 53	Double Beep	0 - Computer Monitor 1 - Visual Display	Triple Beep	Computer Monitor
Input Computer Monitor	To Select To Verify	54 55	Double Beep	0 - AA Off 1 - AA On 2 - T/R Off 3 - T/R On 4 - N.B. Off 5 - N.B. On	Triple Beep	AA - Off T/R - Off N.B. - Off
Supervised Trunk Mode	To Select To Verify	56 57	Double Beep	0 - Off 1 - On	Triple Beep	Off
Zone Microphone	To Select To Verify	58 59	Double Beep	0 - Off 1 - On	Triple Beep	Off
Note: Exit the programming mode by dialing #. The # key will terminate a digit string (i.e., Password string).						

Table 2. General Zone and Group Configurations

The Copy Command

Copy Command	Dial 12	Double Beep	Enter zone number that is to be copied.	Double Beep	Enter the beginning of the range.	Double Beep	Enter end of the range	Triple Beep
---------------------	---------	-------------	---	-------------	-----------------------------------	-------------	------------------------	-------------

Feature	Mode Option/Verify	Dial	Listen For	Zone or Group Selection	Listen For	Choose Option	Listen For	Default
Zone Map	To Select To Verify	60 61	Double Beep	Enter physical zone or group	Double Beep	Enter alias zone/group	Triple Beep	None

				number.		number		
Type of Zone	To Select To Verify	62 63	Double Beep	Enter Zone or group number.	Double Beep	0 – Output 1 – Input 1 2 – Input 2	Triple Beep	Output
Zone Grouping	To Select To Verify	64 65	Double Beep	Enter Group Number.	Double Beep	Enter zone numbers. A # will terminate the string.	Triple Beep	None
Remote Monitor	To Select To Verify	66 67	Double Beep	Enter zone or group number.	Double Beep	0 – Off 1 - On	Triple Beep	Off
<p>*Notes:</p> <p>1. When a Zone map number (ALIAS) is changed, all of the previous options for that zone will be transferred to the new zone.</p> <p>2. Program the Controller using (ALIAS) numbers, if optioned. Otherwise, use the physical zone/group numbers. Exit the programming mode by dialing #.</p> <p>3. The # key will terminate a digit string (i.e., Zone Numbering string).</p>								

Table 3. Output Zone or Group Configurations

Feature	Mode/Option Verify	Dial	Listen For	Zone/Group Selection	Listen For	Choose Option	Listen For	Default
Type of Output	To Select To Verify	70 71	Double Beep	Enter Zone Number	Double Beep	0 –Audio/ N.O. 1 – Mom. Open 2 –N/C 3 – Sys HS 4 –Toggle 5 – Phantom 6 – AA Ready	Triple Beep	Audio/ N.O.
Page Enable	To Select To Verify	72 73	Double Beep	Enter Zone or Group Number	Double Beep	0 – NO 1 - YES	Triple Beep	Yes
Music Enable	To Select To Verify	74 75	Double Beep	Enter Zone Number	Double Beep	0 – NO 1 - YES	Triple Beep	No
TalkbackEnable	To Select To Verify	76 77	Double Beep	Enter Zone or Group Number	Double Beep	0 – NO 1 - YES	Triple Beep	No
Night Bell Enable	To Select To Verify	78 79	Double Beep	Enter Zone Number	Double Beep	0 – NO 1 - YES	Triple Beep	No
Pass DTMF to the Output	To Select To Verify	90 91	Double Beep	Enter Zone or Group Number	Double Beep	0 – NO 1 - YES	Triple Beep	No

Table 4. Input Zone and Group Configurations

Feature	Mode/Option Verify	Dial	Listen For	Zone or Group Selection	Listen For	Choose Option	Listen For	Default
Activate Tone via an Input Closure	To Select To Verify	92 93	Double Beep	Enter the input zone number	Double Beep	0 - None 1 - Chime 2 - Siren 3 –Warble Siren 4 – Night Bell 5 - Fast Ring 6 – Steady Tone 7 – Door Bell	Triple Beep	None
Tone Routing	To Select To Verify	94 95	Double Beep	Enter the input zone number	Double Beep	Output zone/group number	Triple Beep	None

Audio Source Enabled	To Select To Verify	96 97	Double Beep	Enter the input zone number	Double Beep	0 – None 1 – AA 2 – T/R	Triple Beep	None
Audio Routing	To Select To Verify	98 99	Double Beep	Enter the input zone number	Double Beep	Output zone or group number	Triple Beep	None
Note:								
<ol style="list-style-type: none"> 1. Program the PagePac Plus using the ALIAS numbers, if optioned. Otherwise, use Physical zone or group numbers. 2. Exit the programming mode by dialing #. 3. The # key will terminate a digit string (i.e. Zone Numbers string). 								

ZONE MAP AND ZONE CONFIGURATION TABLES

1. Write a brief description of each zone.
For example, Lobby, Warehouse, Doorbell: Security Door, Fire alarm, etc.
2. Assign ALIAS Zone Numbers (optional).

Assign an Alias Zone Number if the extension number needs to be 3 or 4 digits. You dial to reach this zone if an ALIAS number is *assigned to any zone*, *ALIAS numbers must be assigned to ALL zones*.

3. Enter the Input or Output zone type.
Write an I-1, I-2, or an O to indicate the type of zone. I-1 means input priority level 1; I-2 means input priority 2 (the higher priority zones get first access to the Controller). Input and Output here mean inputs to, or outputs from, the Controller.
4. Fill in description of Output Zone.
See examples in step one. Refer to the Zone Map.
5. Enter the Type of Output.
The options are Audio/N.O., Mom. Open, N-C, Sys HS, Toggle, Phantom, or AA Ready.
6. For the other features listed for that zone, enter a Y (yes) or N (no) to implement those options.
7. Fill in description of Input Zone.
See examples in step one. Refer to the Zone Map.
8. Enter the Priority Level (1 or 2) for this zone.
Priority Level 1 inputs are “first in” to access the page.
9. Select Tone 1 - 7 for this zone (refer to Tone Selection descriptions).
10. Enter the Zone or Zone Group to receive the tone.
Refer to Zone map to determine what zones will hear this tone.
11. Enter 0, 1, or 2 for Audio Enable to this zone.
0 = None, 1 = AA, Attendant Access, and 2 = T/R Telephone Access (refer to Program **96** Audio Source Enable).
12. Enter the zone number to route the audio to.
Refer to Program **98**, Set Audio Routing, for an explanation of this feature.
13. Upon completion of the Zone Map and Zone Configuration Tables, begin Programming System.

Table 5. Zone Map

Description Of Zone	Physical Zone Number	Physical Zone Code	ALIAS Zone Number	Input (1or 2) or Output
	Zone 1	01		
	Zone 2	02		
	Zone 3	03		
	Zone4	04		
	Zone 5	05		
	Zone 6	06		
	Zone 7	07		

	Zone 8	08		
	All Call	80		
	Group 1	81		
	Group 2	82		
	Group 3	83		
	Group 4	84		
	Group 5	85		
	Group 6	86		
	Group 7	87		
	Group 8	88		

Zones 9 thru 24 are located on the First Zone Expansion Unit.

	Zone 9	09		
	Zone 10	10		
	Zone 11	11		
	Zone 12	12		
	Zone 13	13		
	Zone 14	14		
	Zone 15	15		
	Zone 16	16		
	Zone 17	17		
	Zone 18	18		
	Zone 19	19		
	Zone 20	20		
	Zone 21	21		
	Zone 22	22		
	Zone 23	23		
	Zone 24	24		

Table 5. Zone Map

Zones 25 thru 40 are located on the Second Zone Expansion Unit.

Description of Zone	Physical Zone Number	Physical Zone Code	ALIAS Zone Number	Input (1 or 2) or Output
	Zone 25	25		
	Zone 26	26		
	Zone 27	27		
	Zone 28	28		
	Zone 29	29		
	Zone 30	30		

	Zone 31	31		
	Zone 32	32		
	Zone 33	33		
	Zone 34	34		
	Zone 35	35		
	Zone 36	36		
	Zone 37	37		
	Zone 38	38		
	Zone 39	39		
	Zone 40	40		

. Zones 41 thru 56 are located on the Third Zone Expansion Unit.

	Zone 41	41		
	Zone 42	42		
	Zone 43	43		
	Zone 44	44		
	Zone 45	45		
	Zone 46	46		
	Zone 47	47		
	Zone 48	48		
	Zone 49	49		
	Zone 50	50		
	Zone 51	51		
	Zone 52	52		
	Zone 53	53		
	Zone 54	54		
	Zone 55	55		
	Zone 56	56		

Table 6.Zone Configuration Table (Output Zones)

Description Of Output Zone	Phys Zone Code	Type of Output	Page Enable Y/N	Music Enable Y/N	Talk Back Enable Y/N	Night Bell Enable Y/N	DTMF Pass thru Y/N
Example							
i.e., Office Loudspeaker	01	Audio	Y	Y	N	Y	N

	Weight: 3.00 pounds (1.36kg)
Electrical: 0...dBu Output	Voltage: 0.388Vrms (no load) Impedance: 11 Ohms
0 dBu Output	Voltage: 0.388 Vrms (no load) Impedance: 11 Ohms
Page Compression Threshold	-12 dBm at Tip/Ring and Attendant Access inputs.
Talkback Compression Threshold	-15 dBm (measured at Tip/Ring)
Frequency Response Tip/Ring	-3 dB \pm 1 dB at 350 Hz and 20 kHz
Frequency Response (Attendant Access)	-3 dB \pm 1 dB at 200 Hz and 20 kHz
Talkback Sensitivity	138 mVrms at the 0 dbm output (pins ½, J3); 4mVrms zone output.
Talkback Compression	-15 dBm \pm 2 dB measured Tip and Ring
Telephone Interference: Dry Loop Loop Start and Ground Start Station/Centrex Access	Impedance: 600 Ohms; Control Lead De-bounce: 50 msec. Impedance: 600 Ohms; Talk Battery; - 24 VDC; Control Lead De-bounce; 150 msec. Impedance: 600 Ohms; Open Interval Protection: 1.2 seconds: Forward Disconnect; greater than 400 msec.
Attendant Access Interface	Impedance: 40 K Ohms(Balanced); 20 K Ohms (un-balanced). Control Lead De-bounce; 50 msec.
Relay Contacts	Control Contact Closure: Contacts are rated at 120vac/50vdc and 1 Amp. Audio Zone: Contacts are rated at 2 Amps.
Temperature Range:	0 to+40 deg. C. (32 to 104 deg.F) storage and shipment -40 to +66 degrees C. (- 40to +150 degree F) storage and shipment.
Humidity Range:	5% to 95% (non – condensing) storage/shipment and operation.
Altitude:	Sea level to 10,000 ft. operational (1048 to648 millibars); 40,000 ft max. shipment.
Air Pressure:	40,000 feet maximum shipment
Environmental	Locate in an area free of excess moisture, corrosive gasses, dust, and chemicals.
Interconnect Cable	8 – position, 5 Amp contact rating, locking, keyed, 22 AWG wire, housing material 94 Volt-2, U.L. and C.S.A. listed, providing 70 Vrms (4), common ground, +17 VDC and -24 VDC.

CONTROLS AND INDICATORS, TERMINALS AND CONNECTORS

Figure 19 shows the controls and indicators, terminals and connectors on the rear panel of the AmpliCenter, Controllers, and Zone Expansion Units. Table 9 identifies them by function.

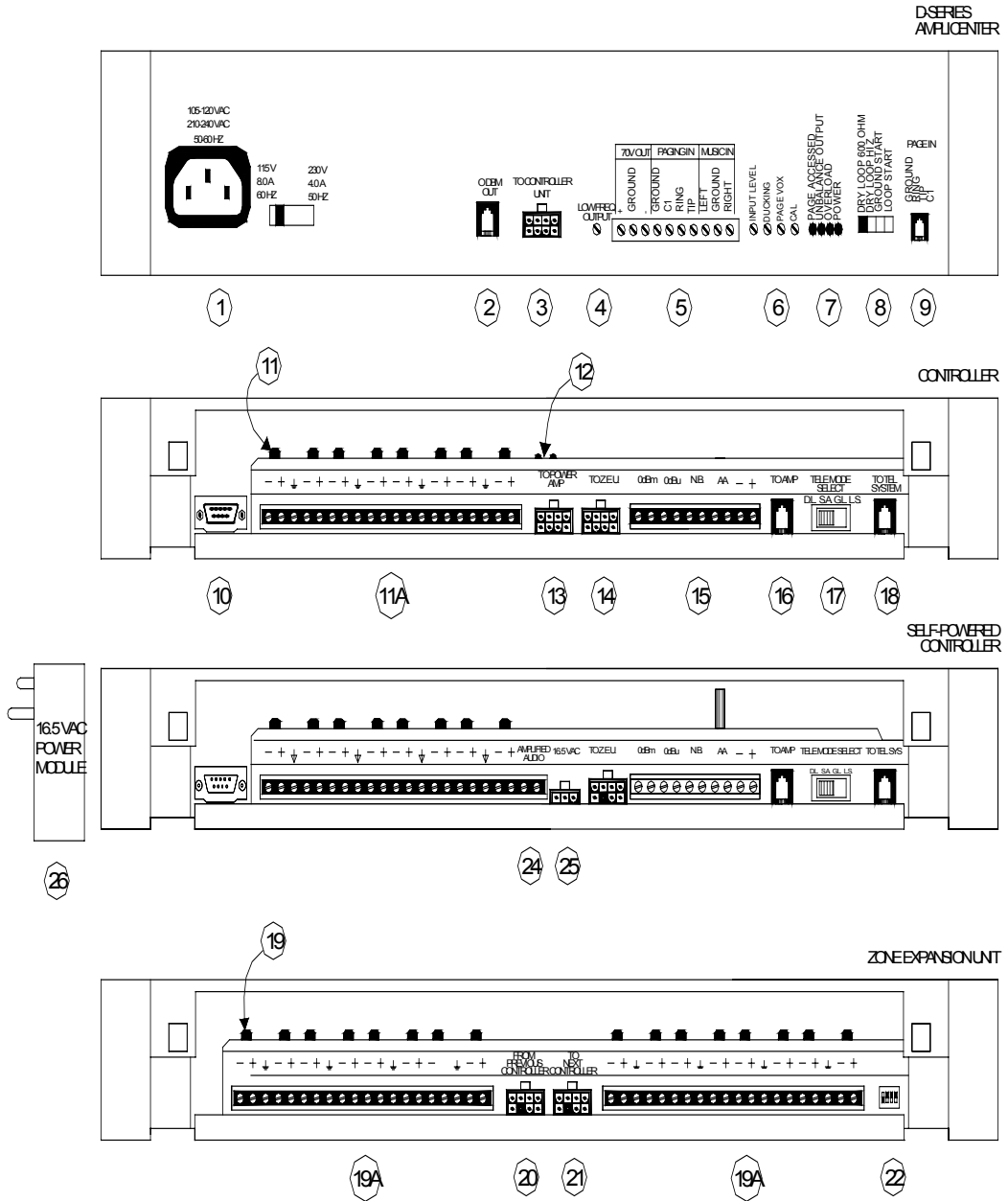

Figure 19. AmpliCenter, Controllers, and Zone Expansion Unit Back Panels

Table 9. Controls and Indicators, Terminals and Connectors

1.	AC Power in: 105 – 125 VAC, 210 – 250 VAC, 50/60 Hz. (voltage auto- selectable within unit).
2.	0 dBm out, an auxiliary output that differs from the main 70.70 Volt output in that it is a low level (0 dB), 600 Ohm balanced output used for driving a remote or off – premises amplifier.
3.	8-pin Molex connector DC Power: and 70 Volt audio out to standard Controller (Not used on self – powered Controller).
4.	Low Frequency cut-off bass control adjustment. Attenuates low frequencies so that the horns and small speakers are not over driven by excessive bass energy. Cut – off frequency adjustable from 50 Hz (full CCW) to 400 Hz (fullCW).
5.	Music In: Left and/or right channels with ground; Paging in: redundant paging input (ground, C1, tip, and ring): 70 Volt out: Balanced output used for terminating the loud speaker wiring.
6.	Screw adjustable potentiometers: page VOX sensitivity level, Ducking (mute level for music during voice page), Input level for various music sources.
7.	LEDS: Green: Page accessed, lights when voice paging is active Red: .Unbalanced output, indicates when one speaker lead is accidentally shorted to ground. Red: Overload, Lights when the AmpliCenter output exceeds its output power rating. This can occur when total speaker load is greater than the output rating, or when Speaker wiring is shorted. Green: Power on, lights when AC line voltage is applied to AmpliCenter.
8.	Telephone system mode switch: dry loop 600 Ohms, dry loop HiZ, ground start, or loop start.
9.	Page input from host telephone system or controller 6 – conductor cable (see item16): paging audio and control.
10.	DB9 connector, RS – 232 PC interface port, used for PC programming of Controller and PC monitoring.
11.	Zone option 3 position slide switch: 70 Volt audio out, contact closure input, contact closure output.
11A	Zone connector for zones 1 – 8, plus, minus, and ground screw terminals.
12.	LEDs: Yellow – attendant access active: Green – telephone access active.
13.	8 – pin Molex connector: DC power, control, and 70 Volt audio from AmpliCenter.
14.	DC power, control, and 70 volt audio output to Zone Expansion Unit.
15.	10 – position connector: terminals ½) dBm (600 Ohm), terminals ¾ 0 dBu to other equipment, terminals 5/6 night bell in, terminal 7/8 control closure for attendant access input, terminals 9/10 audio source (mic) attendant access input.
16.	Audio and control to AmpliCenter 6 – conductor jack, item #9.
17.	Telephone Mode switch: Dry loop, Station Access, Ground Start, and Loop Start.
18.	CO Port, Auxiliary Poet, Analog Extension or Centrex systems: standard 6 – conductor jack.
19.	Zone option 3 position slide switch: 70 Volt audio out, contact closure input, contact closure output.
19A	Zone connector for expansion zones: plus, minus and ground screw terminals.
20.	8 – pin Molex connector from controller: power, control and 70 Volt audio or previous Zone Expansion Unit.
21.	8 – pin Moles connector to additional Zone Expansion Unit : power, control and audio.
22.	Dip switch to be set when one, two or three Zone Expansion Units(s) are used.
23.	Volume output control on self – powered Controller.
24.	Amplified audio input terminals on self – powered Controller.
25.	Power connector input for 16.50 Volt power module on self – powered Controller.
26.	AC power transformer to self – powered Controller: 120 VAC, 60 Hz, 200 mA to 16.5 VAC.

PAGE PAC PLUS CONTROLLER ACCESS OPTIONS:

The **Dry Loop 600 Ohm** is a four wire interface consisting of a dry audio pair with a 600 Ohm impedance and a control pair. The page input is activated when the control pair receives a contact closure from the host

equipment. This feature is beneficial for page port of telephone system with control contact closure pair and DTMF signaling..

Station access/CO mode is for access from PBX analog station, centrex or central office lines, providing 90 VAC ring voltage and 400 milisecond disconnect supervision.

The **Ground Start** mode is a two wire interface and has a 600 Ohm input impedance. When a trunk is accessed, a momentary ground is sent to the ring-side of the pair by the host equipment, loop current is detected and the tip-side of the pair is closed. Disconnect supervision of the ground start mode is accomplished by monitoring the loop current.

Note: Ground start interface requires common ground between paging input and telephone system by direct line or other common grounding methods.

The **Loop Start** mode is two wire interface and has a 600 Ohm input impedance. The host equipment draws loop current from the talk-battery which is supplied by the Controller. Disconnect supervision of the loop start mode is accomplished by monitoring the loop current.

TROUBLESHOOTING

Table 10. Troubleshooting

Problems	Corrective Action
Power LED not on	Verify power cord is connected at both ends.
	Check for AC voltage at the wall socket.
	8 – pin Molex plug from AmpliCenter is wrong connector on Controller
	AmpliCenter or Power Pack failed. Return for repair
Page access extension does not answer.	No power to AmpliCenter.
	Host telephone system not passing call through to Controller.
	Telephone mode option switch on Controller not set correctly.
	Ground Start – Tip and Ring reversed or Controller not grounded to host system.
Background music cannot be heard.	Input level not set correctly. Adjust music input level on AmpliCenter.
	No power to music source. Verify power is on.
	Radio off station. Adjust tuner.
	A higher priority input is active
	Music input wires crossed, with signal ground out.
Distorted, garbled or raspy sound from all speakers.	Check programming options for music enable.
	Short circuited speaker leads. Separate.
	Music input level too high. Turn down.
	Speaker leads grounded.
	Speaker transformer shorted. Replace.
Page access LED won't go off.	Failed AmpliCenter. Return for repair.
	Page VOX not set to full counterclockwise position.
	C1 lead inadvertently grounded. If loop start or ground start, check that only 2 wires (Tip and Ring) are connected by modular plug cord.
	Incorrect modular to modular cord connected between the Controller and the modular jack of the D – series AmpliCenter.
Talkback feature does not work.	Check the zone option switch, make sure that the switch is in the 70 Volt position.
	Check programming options for talkback enable.
	Check the telephone mode switch on the AmpliCenter is set to Dry Loop, 600 Ohms mode.
Noisy Talkback.	Check wire to see if shielded cable was used. Change to shielded if necessary.
	Make sure shield for cable is only connected to the Controller or Zone Expansion Unit end.
	Remove shield at speaker cord.
Remote amplifier not receiving audio	Check audio connections on) dBm or) dBu.
	Check the zone option switch is in the Contact Closure Output position.

Table 10. Troubleshooting (Continued)

Problems	Corrective Action
-----------------	--------------------------

No music source connected to the input but there is noise on the output in the music mode.	Turn the music input volume control to the full counter clockwise position (down).
	Check programming option to see if music is disabled to the zone(s).
Night Bell is not active when it is intended to be activated with a ring voltage.	The input voltage level is too low or missing (50 Volts or greater is required).
	Make sure the Controller input connections are to pins 5 and 6 of J13.
	A higher priority in the Controller is active.
Zone options as a "Contact Closure Input" is not functioning.	Check the connections to the zone selected as the input zone.
	Check that the zone option switch is in the middle position.
	Using an ohmmeter, verify that a contact closure is being provided from the host equipment.
	A higher priority in the Controller is active.
No "Phone System Enabled" LED is lit when the host system is attempting to access the Controller.	Check the programming options for the proper settings.
	Verify that the Telephone Mode selection switch is in the proper position for the host system interface port.
Relay chatter when Tip and Ring is connected to the Controller.	Check all the connections to J4 on the Controller.
	Verify that the Telephone Mode switch on the Controller is set correctly for the host telephone system.
A busy signal is returned when attempting to make a page from host system page port.	Verify that the Telephone Mode switch is in the "DL" position to match the host telephone system interface port.
	Verify Attendant Access is not active.
	Page port of host system is busy.
Cannot access Controller when Tel. Mode is Ground Start.	Verify host telephone system's ground is connected to terminal "G" of J3 on the Controller.
	Verify Telephone Mode switch on Controller is set to "GS" (ground start).
	Tip and Ring telephone interface connections may be reversed (Ring always more negative than Tip).
Controller answers a station call, then immediately hangs up.	Telephone Mode switch has wrong setting. Set to the "SA" (station access) position to match the host telephone system interface port.
Dial tone or confirmation tone is sent to the speaker when the Controller has not been accessed.	The Telephone Mode switch position may have changed while connecting Tip and Ring wires.
Contact closure output is not functioning.	Check connections to selected contact closure output zone.
	Verify Zone Option switch is in back position for contact closure output.
	Use an ohmmeter to verify that a contact is being provided from the Controller.
	A higher priority access to the Controller is currently active
Attendant Access is not functioning.	Verify programming options enable contact closure output for that zone.
	Check the connection to the Controller back panel, terminals 7, 8, 9 and 10.
	Using an ohmmeter, verify that a contact closure is being provided from the host telephone system to activate attendant access page on the Controller.

TECHNICAL ASSISTANCE

When calling, have a VOM and a telephone test set available and call from the job site. Call (540) 563-2000 and press 1 for PagePac Technical Support or visit our websites at <http://www.pagepac.com> and www.valcom.com.

Should repairs be necessary, attach a tag to the unit clearly stating company name, address, phone number, contact person, and the nature of the problem. Send the unit to:

**Valcom, Inc.
PagePac® Repair Dept.
5614 Hollins Road
Roanoke, VA 24019-5056**

APPLICATION NOTES

NIGHT BELL

There are two different Night Bell connections possible to the Controller. These are illustrated in Figure 20.

From an Electronic Key Telephone System

A programmer needs to know what type of Night Bell connection exists between the telephone system and the Controller. In one case, typically with a Key telephone system, where the phone system produces a contact closure. Night Bell input is wired to one of the eight Controller zones then you will need to configure it as an input zone.

Required Programming: Type of Zone, Program **6 2** , Tone Selection, Program **9 2** and Tone Routing, Program **9 4**. Set the Controller Zone option switch to contact closure input. (see Figure 20).

From a PBX or Centrex System

In the other case, typically with a PBX system that produces a ring voltage output, the Night Bell connection is not wired to one of the eight input zones, but to the connector on the rear of the Controller labeled "N.B." pins 5 and 6, nightbell. (see Figure 2 0)

Required Programming: Night Bell Enable, program 78.

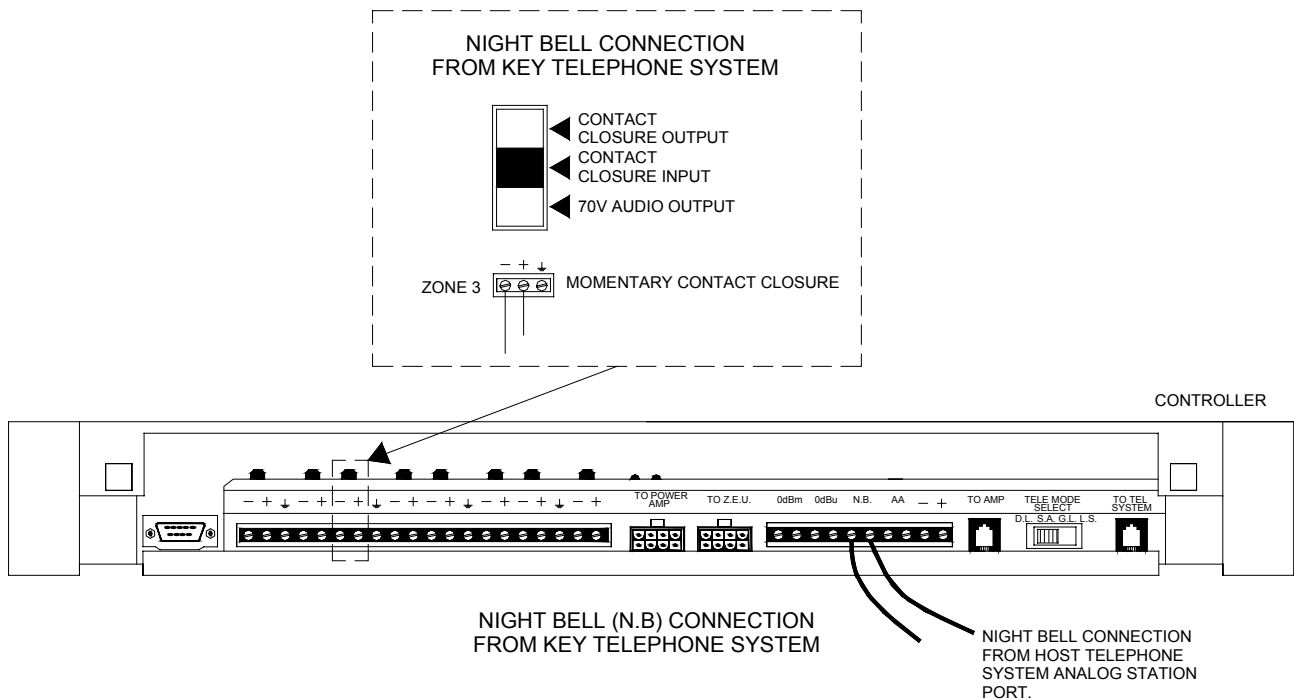

Figure 20. Night Bell Interfaces

DOOR SPEAKER AND DOOR LOCK CONTROL

Visitor Presses Doorbell

Figure 21 illustrates door speaker and control interfaces.

When a visitor presses the doorbell of a security door, a contact-closure input to the controller signals an output tone (i.e., a door chime) to selected paging zone(s).

Required Programming: Type of Zone, Program **6 2** (doorbell as an input zone), Tone Selection, Program **9 2** (select a tone to be sounded when the doorbell input is activated), Tone Routing, program 94 (route the tone to paging zones), and Audio Enable, program **9 6** (so that it automatically opens an audio channel between the door speaker and your telephone access (or attendant access)).

Program **98** to program zone number to enable connection to door speaker.

Answering the Doorbell

The person inside the building, having heard the door chime, can simply dial the proper extension and establish two-way communications with the door speaker.

If the input zone (door bell) has been optioned for Audio Enable, then the user's telephone access (or attendant access, depending on the option chosen in Audio Enable) connects via the paging system to the door speaker, for a period of 10 seconds. If the user doesn't pick up the phone until after the 10 seconds has passed, he must dial the Door Speaker zone code to talk.

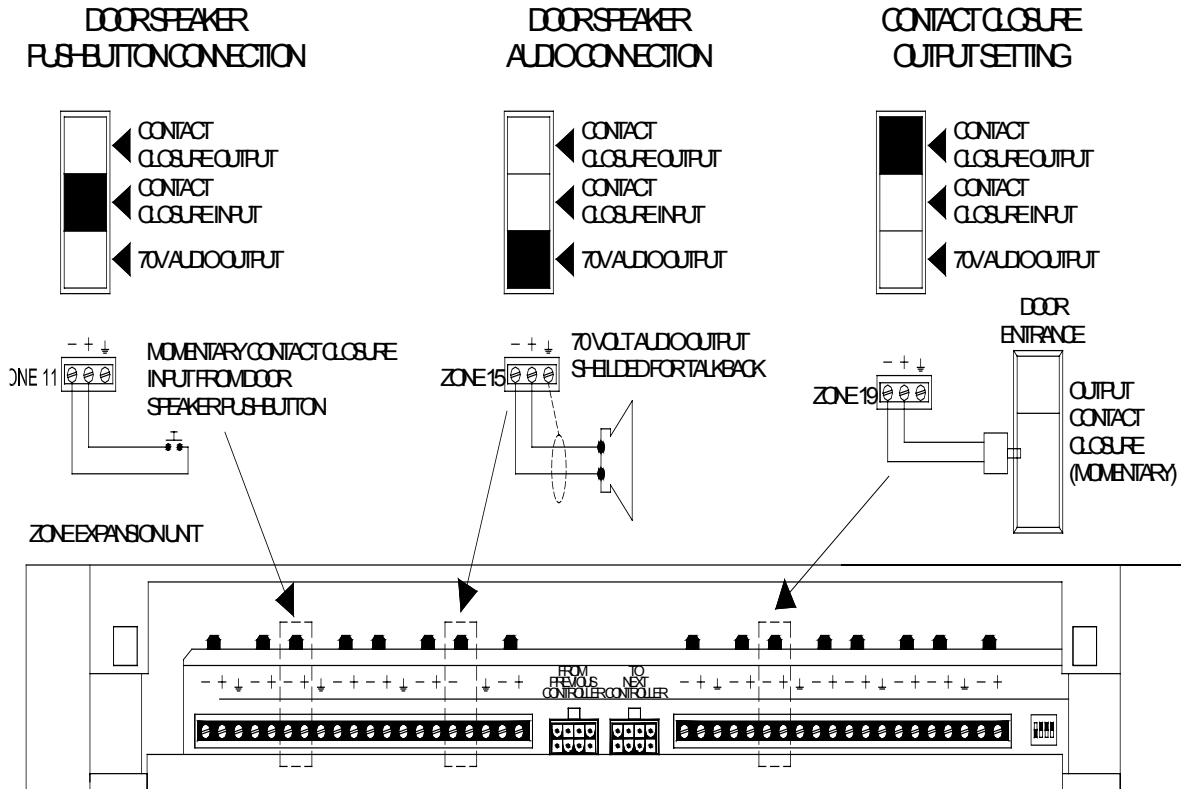

Figure 21. Door Speaker and Control Interfaces

Fi

If the doorbell input has a higher priority than T/A (i.e., is Input #1), and is activated while T/A paging is in progress, or during a dial tone, then the user will hear the door chime tone and be automatically routed to the door speaker for two-way communication.

Required Programming: Type of Zone, Program **62** (interface the door speaker- phone as an output zone), Output Zone Type, Program **70**, (configure output for Audio to the door speaker-phone), Page Enable, step 22, (enables page to the door speaker), Talkback Enable, Program **76** (enable talk-back for the door speaker), and Audio Routing, Program **98** (route the telephone access audio to the door speaker-phone).

Door Unlock

The person inside the building can also remotely unlock the door, by entering a numeric code (Door Code) on the telephone's keypad.

Required Programming: Type of Zone, program **62**, (set the door lock device as an output zone), and Output Zone Type, program **70** (momentary, normally-open switch).

Note: The door ajar switch, if any, should be programmed similarly to a doorbell as an input zone, resulting in a tone.

ALARM SYSTEM INPUT

Figure 22 illustrates a typical alarm system interface. When the alarm system is tripped, a tone will be constantly sent to selected zones until the alarm is reset.

Required Programming: Type of Zone, Program **6 2**, (set the alarm system as Input #1, Tone Selection, Program **9 2** (select a tone to be sounded when the alarm input is activated), Tone Routing, Program **9 4** (route the tone to in-facility paging zones).

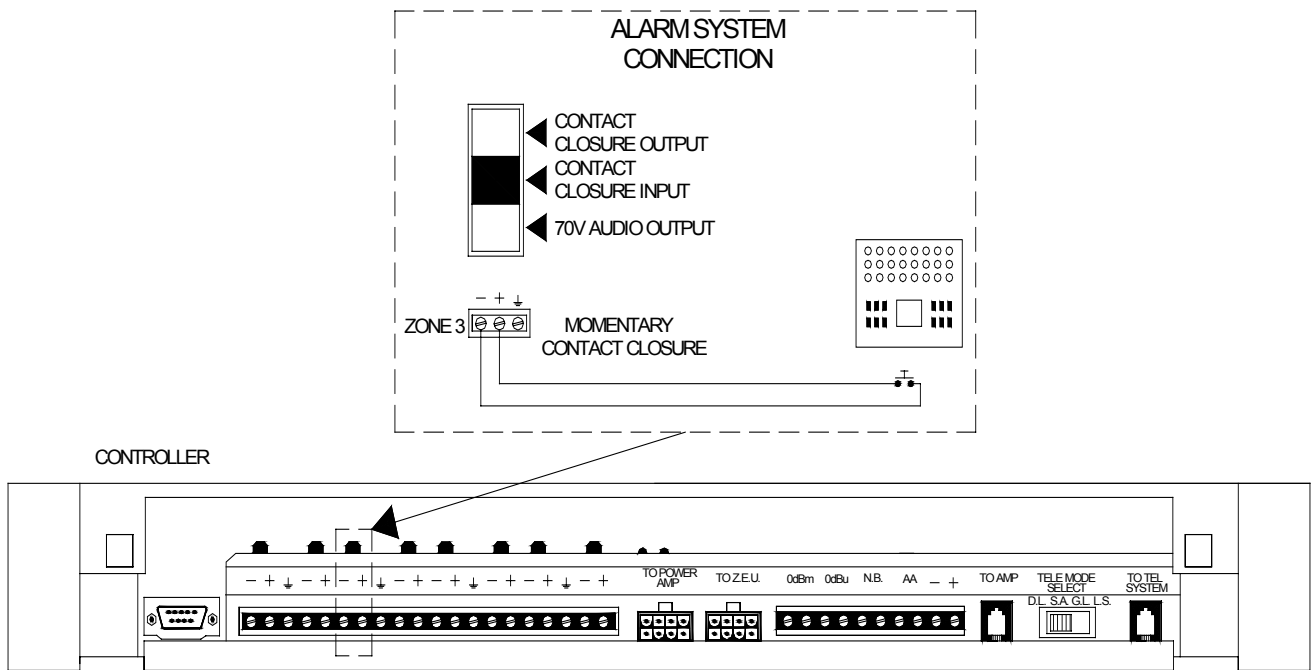

Figure 22. Alarm System Interfaces

COMPUTER MONITOR AND VISUAL MESSAGE DISPLAY

Figure 23 illustrates the Computer Monitor and Visual Display interface.

If a PC computer is connected to the RS-232 port of the Controller for the purpose of logging paging activities, you will need to program the Controller to send signals to it, and turn ON/OFF the Attendant Access, Telephone Access, and Night Bell signals that would be included in the monitor event log.

To communicate with a visual display, you will need to set the Computer Monitor option to Visual Display, and enable the Input Monitor and Remote Monitor options for the interfaces, zones, and zone groups you wish to monitor. You can also use the Phantom option of the Zone Output type parameter.

In addition, you will need to program the visual display with the messages you wish to display.

Required Programming: Computer Monitor, Program **5 2** (set to Computer Monitor or Visual Display), Input to Computer Monitor, Program **5 4** (select monitor types).

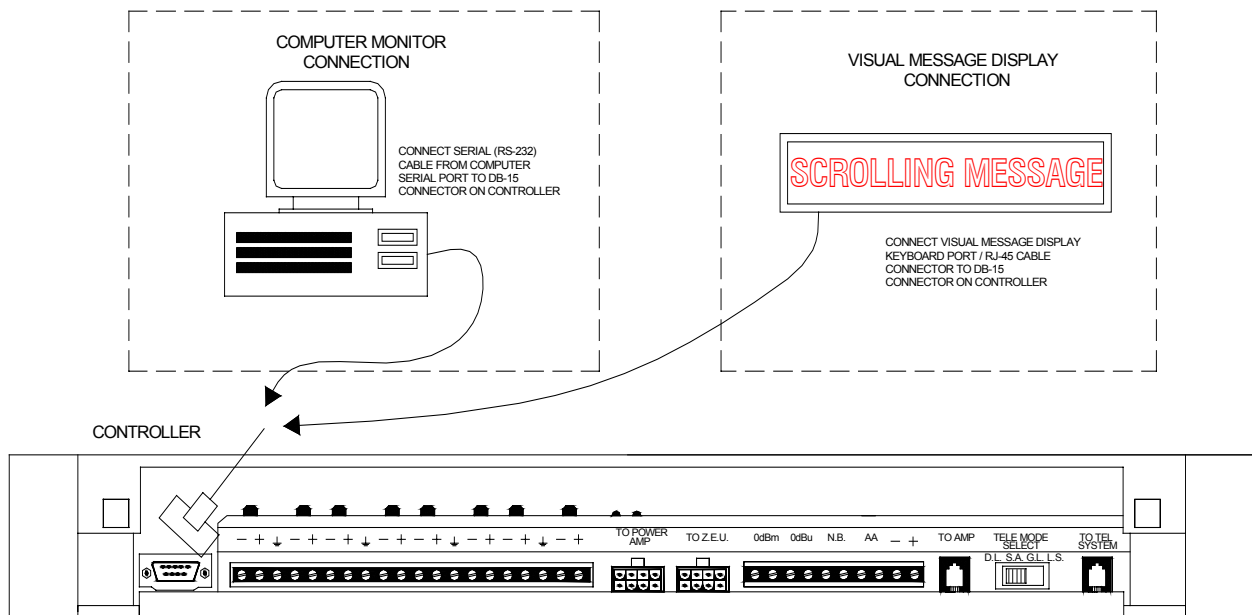

Figure 23. Computer Monitor and Visual Display Interfaces

TALKBACK

Any audio output zone can be programmed for talkback. Each Talkback Paging Zone must use shielded cable, with the shield grounded at the Controller Zone Connector, not the speaker. All speakers in a zone will be two-way speakers, if talkback has been enabled for a zone. Therefore all speakers in the talkback zone will pick up

ambient noise, as well as the voices of persons addressing the paging speakers. For that reason, it is not recommended to have more than two speakers in a zone that is designated for talkback. There should be low ambient background noise levels of 72 dB or less for efficient operation.

Required Programming: Type of Zone, Program **6 2** (set to Output), Talkback Enable, Program **7 6**. (activates two-way speakers).

CONNECTING ADDITIONAL CONTROLLERS OR REMOTE AMPLIFIERS

Figure 24 illustrates the additional Controller and Remote AmpliCenter interface.

When additional Controller(s) or AmpliCenters are daisy-chained with the first Controller, you will want to ensure that the programming option DTMF Enabled to the Output has been selected for a YES condition for output zones. This permits paging by telephone in one zone, to dial another zone number (residing on the remote Controller unit) and automatically reach that zone. Your DTMF dial input tones are passed through the first (main) Controller, to the second one, where a switch of zones occurs in response to the dialed tones.

Required Programming: Type of Zone, Program **6 2** (contact closure output to remote Controller), Enable DTMF to output, Program **9 0** (send tone to remote Controller).

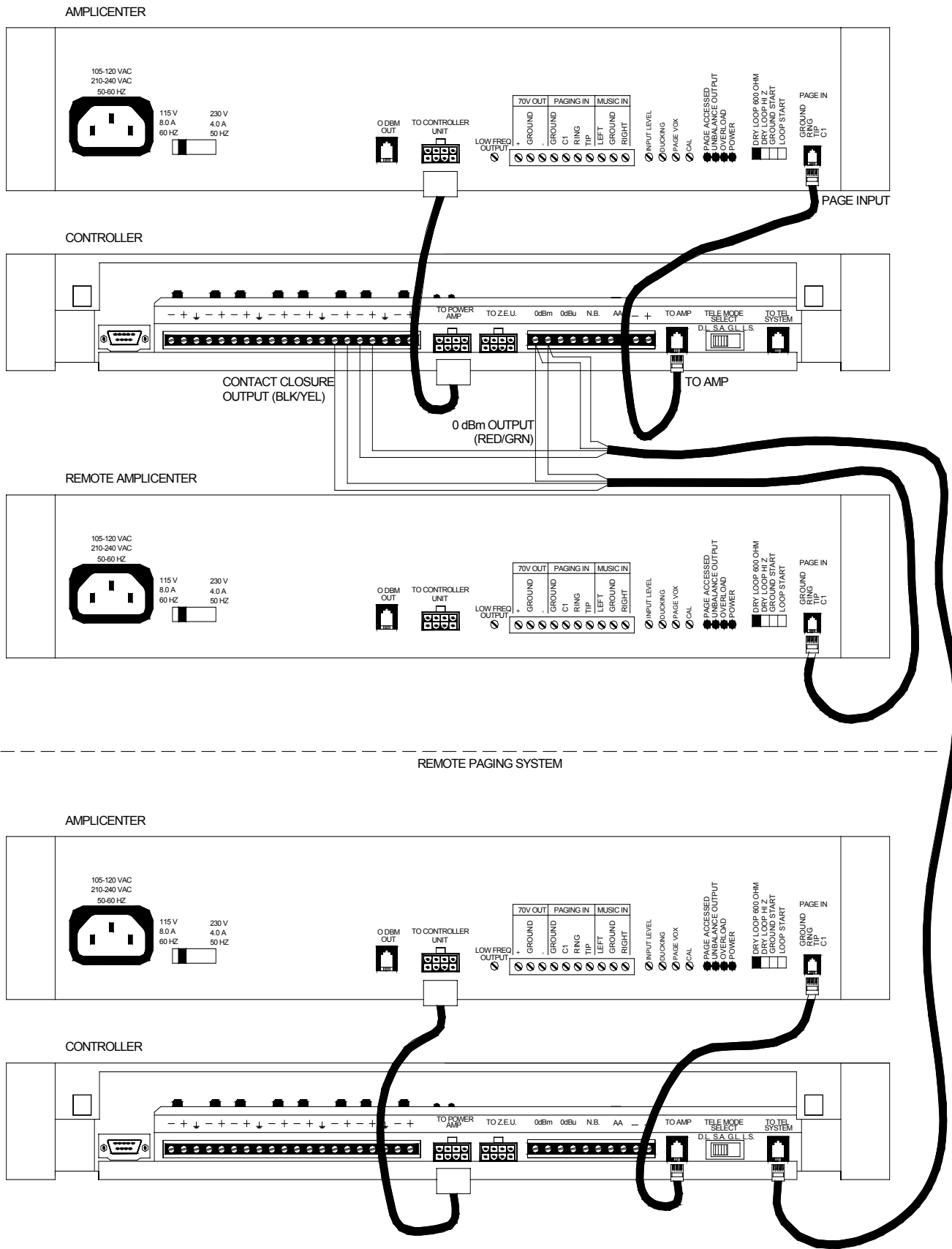

Figure 24. Connecting Additional Controllers and Remote Amplifiers