



800-336-4864

www.tele-movers.com

THREE-LINE TELEPHONE WITH ANSWERING

User Guide



Venture

Multiline Communications

Welcome to Venture — the 3 Line phone/system with a built-in Telephone Answering Device (TAD). The Venture is a fully customizable phone, providing you with big features for the small business or home.

Your Venture’s “system” intelligence is built right into the phone. Therefore, no costly or complicated central control is required. And, the Venture TAD easily connects to your home or office’s existing telephone lines.

The versatility of the Venture TAD allows your phone/system to grow right along with your business or family needs. You can add up to seven other Venture sets to create an efficient, productive and cost effective telephone system. With the further addition of an Enhanced Feature Adaptor, you’ll be able to expand the functionality of your Venture system by adding the ability

to print a detailed record of all calls, play music or even answer your door.

Whether alone or linked to other Venture sets, your Venture TAD provides you with the following big features!

- Answering device — compact because it’s part of your phone and digital so there is no need to replace tapes. With the Venture TAD you will be able to:
 - customize up to 14 separate mailboxes
 - record personal greetings for each mailbox
 - direct callers to specific mailboxes for easy message organization
 - record voice tags so incoming callers will be announced over the speaker
 - record special memos for business colleagues or family members

- pick up your messages from outside the home or office

- program your phone to call you, wherever you may be, when you have messages

- When you subscribe to Caller ID or Caller ID on Call Waiting from your local service provider, you also have the ability to:
 - view the name and number of incoming calls, even Call Waiting calls, before you answer
 - log the name and number of up to 200 incoming calls to easily track and organize calls
- Other exciting Venture features are:
 - 200 name/number Directory
 - high quality speakerphone enabling handsfree conversations
 - 10 call Redial list of outgoing telephone numbers
 - 8 programmable memory keys
 - 20 item Services list

- When you use your Venture TAD within a linked system, you can:
 - call or page between other phones in your system
 - transfer calls between other phones in your system
 - share messages between phones in your system using common lines
 - share a Public Directory between phones in your system
 - generate a list of the names and IDs for phones in your system
 - monitor the line/phone status for phones in your system.

The Venture Display or User Guide...

As you begin to set up and program your Venture TAD, you will notice that the display shows a variety of prompts and icons. Simply read and follow these easy to understand instructions to complete all functions. You can also read this User Guide, which describes in detail, the steps necessary to complete any function.

Venture's Standard Functional Keys

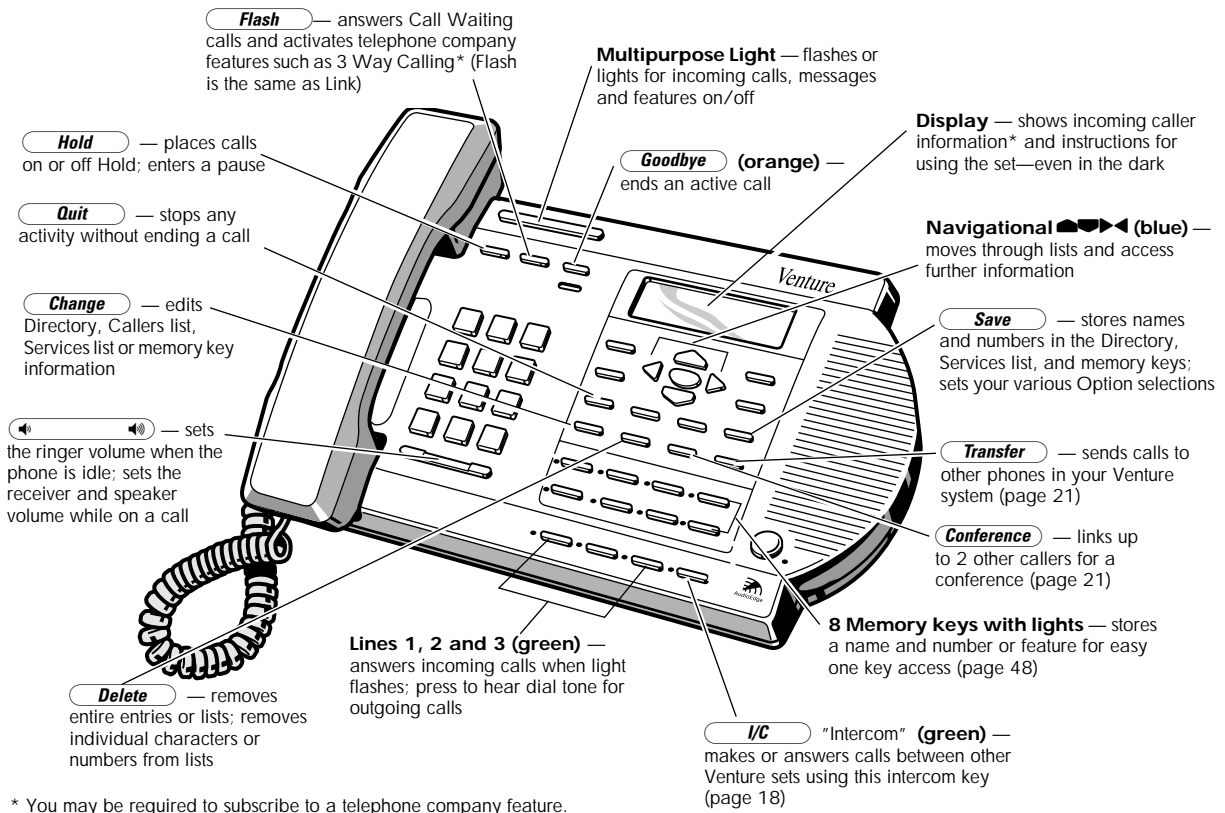

* You may be required to subscribe to a telephone company feature.

Venture's Answering Device and List Keys

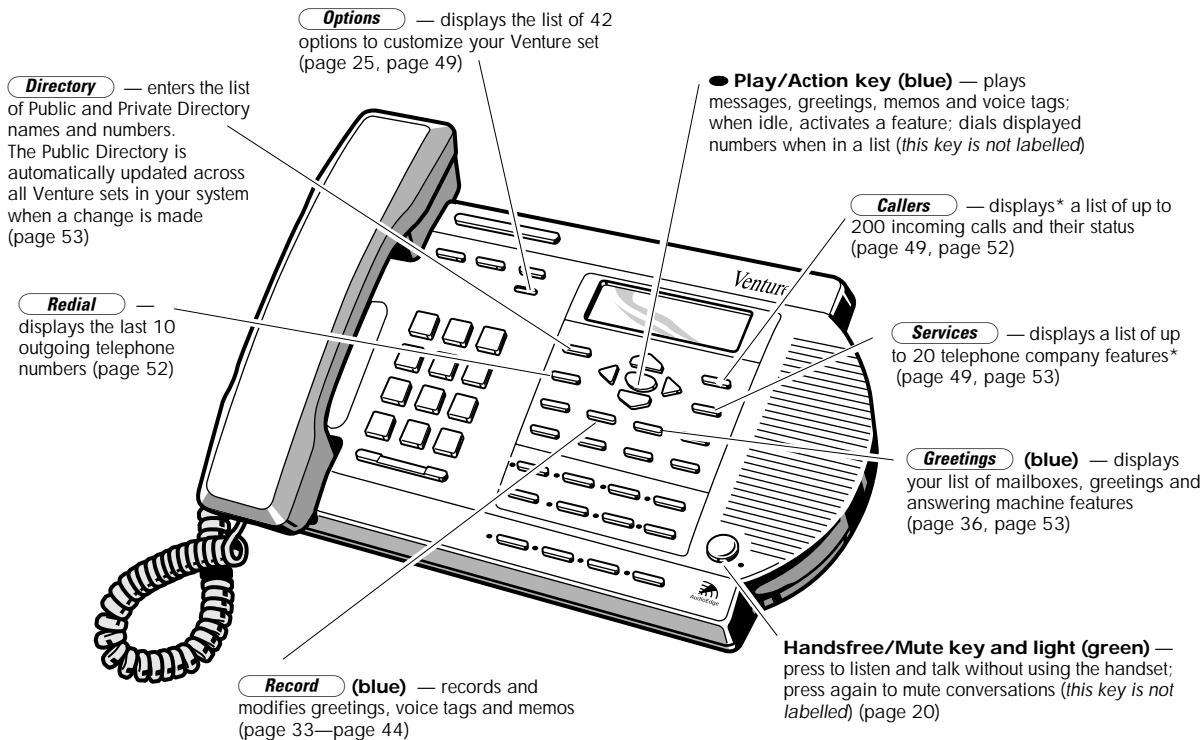

*You may be required to subscribe to or pay a charge for the features.

Unpacking the phone

When you unpack your new Venture TAD phone, ensure that you have all of the parts shown below as well as a User Guide and the Quick Start Card.

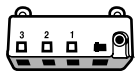

Cord Adapter Module (CAM)

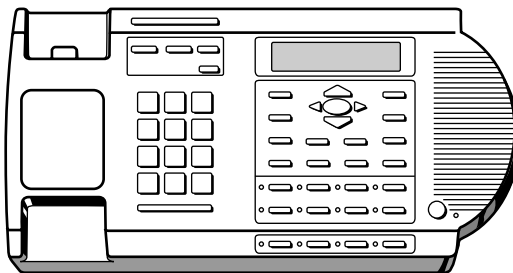

Venture base phone

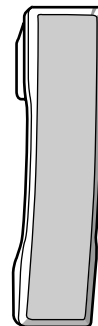

handset



6-wire cords
(silver)



8-wire cords
(black)

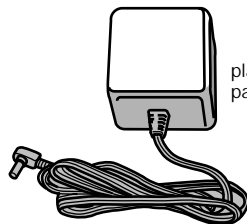

power adapter
and cord

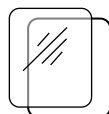

plastic handset lens and
paper labels

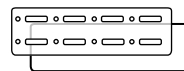

plastic memory key lens
and paper labels

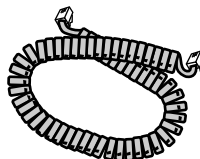

handset cord

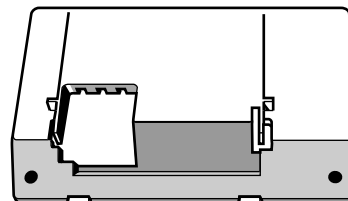

stand

Although there are many possible installation configurations for your Venture with Telephone Answering Device (TAD), you can install the phone/system yourself once you've determined the following:

- 1 the number of Venture phones to be included in the system (up to 8);
- 2 the number of lines you require for each phone;
- 3 the intended location of each Venture phone (ensure that a phone jack and power supply is nearby); and
- 4 phone line configuration.

Phone line configuration

Whether you require extra lines to be installed or are using existing lines, you need to determine the configuration of your telephone lines and jacks. For example, are all three lines available from a single phone jack or does each line have its own

separate phone jack. Your local telephone company can assist you with this determination. You can also review the illustrations on the following pages.

The Installation Planning Worksheet on the next page can assist you in planning your Venture system installation.

Single phone

You can install a single Venture TAD phone using one, two or three separate lines. Simply follow the instructions and review the illustrations on page 9, page 10 or page 11 once you have determined which set up is best suited to your needs.

Multiple Phone System

If you are installing more than one Venture phone, and want them to communicate with each other, **line 1 MUST be the same telephone number for all installed phones in the system.** Although line 1 must be

common, lines 2 and 3 may be the same, different, or some combination on each set.

As well, each phone in your Venture system **MUST** have a unique two-digit phone ID and name assigned to it. As you install each phone, Venture's display prompts you to enter this information. See "Setting up your phone" on page 13.

The following pages guide you through the installation of your Venture system. Please read each section carefully. **It is important that you install one phone at a time and confirm the installation of each set before moving on to the next phone.** This ensures a quick and easy set up of your Venture system.

Important...

Review the instructions and the illustrations on page 9, page 10 and page 11 to help you determine which installation set up is best suited to your needs.

Installation planning worksheet example

Phone ID/ Name	Line 1/Jack	Line 2/Jack	Line 3/Jack	Location
01- Michael	555-4443/ jack 1	555-4444/ jack 1	555-4445/ jack 1	reception
02- Gord	555-4443/ jack 1	555-4444/ jack 1	555-4446/ jack 1	service
03- Carol	555-4443/ jack 1	555-4447/ jack 2		lab

Installation planning worksheet

Phone ID/ Name	Line 1/Jack	Line 2/Jack	Line 3/Jack	Location

Note: The same telephone number **must be** used for line 1 on every phone in your system otherwise phones can not communicate with each other.

Installing the phone



- 1 Disconnect all equipment, such as other phones, faxes, or modems from the lines you will be using for your Venture system. You can reconnect this equipment later, after the Venture system has been installed and checked.
- 2 Review the following configuration drawings to determine which set up is best suited to your individual requirements.
- 3 Install and check one Venture phone at a time.
- 4 Check to see that your Venture system is properly installed and communicating.

☞ *Ensure that you use only those cords provided and in the correct configuration, as described on the following pages.*

The cord adapter module

The Cord Adapter Module (CAM) connects the phone lines and the power adapter to the Venture phone through one 8-wire cord. The CAM has three line ports, labeled as port 1, port 2 and port 3.

- Port 1 provides a connection to Venture lines 1, 2 and 3.
- Port 2 provides a connection to Venture lines 2 and 3 only.
- Port 3 provides a connection to Venture line 3 only.

The phone port, located next to port 1, is used to connect the CAM to the phone . The power port, located on the top of the CAM, is used to connect the CAM through the power adapter to an electrical outlet .

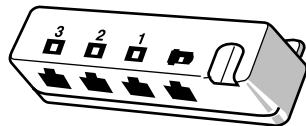

☞ *Only one line cord needs to be routed to a desktop when the CAM is used for line management. This allows you to keep a neat and tidy surface area even when using three separate lines.*

Fax and modem

To install a fax or modem to your Venture phone/system, you should not use line 1. Plug your fax or modem into either the line 2 or line 3 port of the CAM, depending on your system and line configuration.

If you must use line 1 to connect a fax or modem, we recommend that you use a separate wall jack.

One or more lines, one phone jack

1. Plug one end of a grey **6-wire cord** into the phone jack; the other end into port 1 of the CAM.



2. Plug one end of a black **8-wire cord** into the phone port of the CAM, **run the cord through the stand** and plug the other end into the CAM port on the back of phone.





3. Connect the handset cord to the end of the handset. Connect the other end to the back of the base.

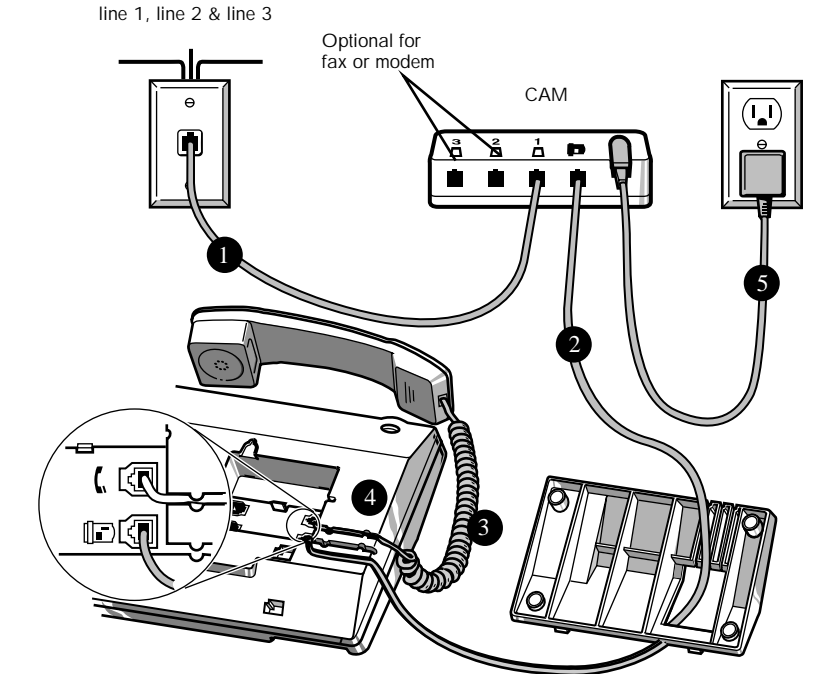

4. Route the handset cord through the bottom right channel on the back of the base.

5. Plug the **power adapter cord** into the power adapter port on the top of the CAM and the **power adapter** into an electrical outlet.



☞ **The ports on the back of the base, bearing the icons  and , are not currently used.**

Two lines, two phone jacks

1. Plug one end of a grey **6-wire cord** to the line 1 phone jack; the other end to port 1 on the CAM.

1 

2. Plug one end of another grey **6-wire cord** to the line 2 phone jack and plug the other end to port 2 on the CAM.

2 

3. Plug one end of a black **8-wire cord** into the phone port of the CAM, **run the cord through the stand** and plug the other end into the CAM port on the back of the phone.







4. Connect the handset cord to the end of the handset. Connect the other end to the back of the base.

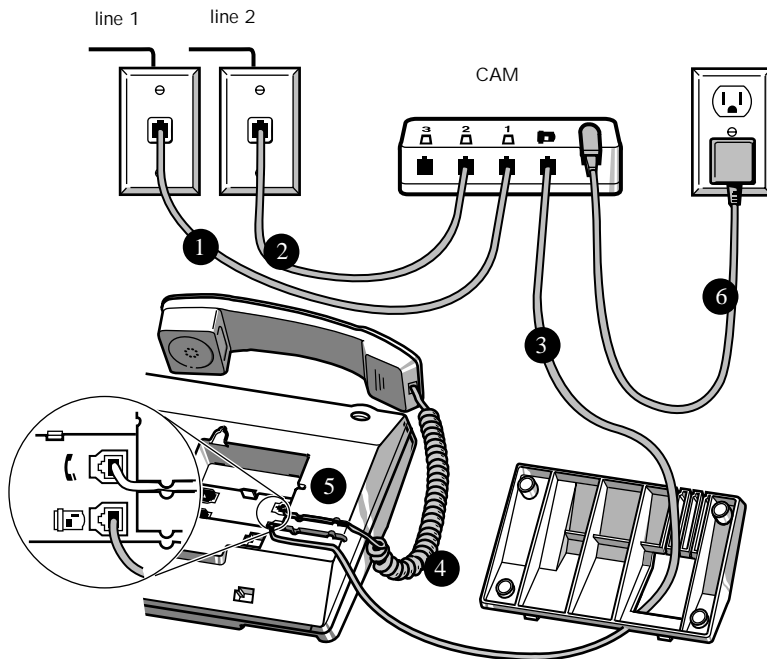

5. Route the handset cord through the bottom right channel on the back of the base.

6. Plug the **power adapter cord** into the power adapter port on the top of the CAM and the **power adapter** into an electrical outlet.



 **The ports on the back of the base, bearing the icons  and , are not currently used.**

Three lines, three phone jacks

1. Connect one end of a grey **6-wire cord** to the line 1 phone jack and plug the other end to port 1 on the CAM.

1 

2. Connect one end of another grey **6-wire cord** to the line 2 phone jack and plug the other end to port 2 on the CAM.

2 

3. Connect one end of another grey **6-wire cord** to the line 3 phone jack and plug the other end to port 3 on the CAM.



3 

4. Plug one end of a black **8-wire cord** into the phone port on the CAM, **run the cord through the stand** and plug the other end into the CAM port on the back of the phone.

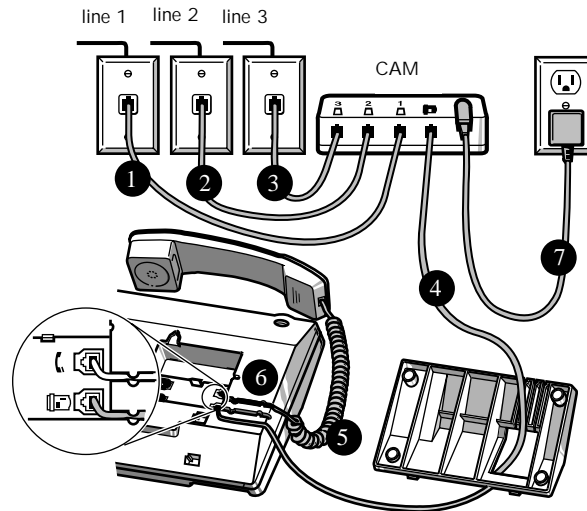

5. Connect the handset cord to the handset. Connect the other end to the back of the base .
6. Route the handset cord through the bottom right channel on the back of the base.
7. Plug the **power adapter cord** into the power adapter port on the top of the CAM and the **power adapter** into an electrical outlet.



 **The ports on the back of the base, bearing the icons  and , are not currently used.**

☞ *For additional configurations see pages 71 through 73.*

Attaching the stand

With the line cord routed through the hole on the stand:

1. Align the tabs on the edge of the stand with the holes on the back of the phone.

☞ *You can adjust the phone to sit at a higher or lower angle by choosing between the two sets of holes on the phone.*

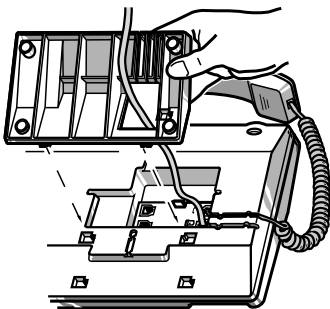

2. Lower the tabs into the holes that you have chosen.

3. Push the stand against the phone until the tabs click into the locking holes.
4. Press the cord into the channels on the bottom of the stand.

Removing the stand

1. Firmly grasp the stand and the phone.
2. Pull hard until the parts separate.

☞ *You will hear a loud cracking sound as the stand separates from the base.*

Installing a phone on a wall

To install a Venture phone on the wall, the wall jack should have a wall mount plate (which can be purchased from your telephone company or from an electronics store) and be configured with all lines on one jack (see the illustration on page 9).

1. Plug one end of the handset cord into the handset port on the back of your phone.
2. Press the cord into the channel provided.
3. Press the CAM into the cavity in the back of your phone.

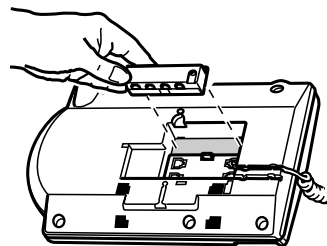

4. Plug one end of the black *short 8-wire* cord to the phone port of your CAM.

5. Plug the other end of the black **short 8-wire** cord into the CAM port on the back of your phone.

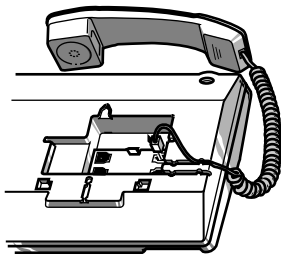

6. Plug the **power adapter cord** into the power adapter port on the CAM.
7. Press the cord into the channel provided.
8. Plug the power adapter into an electrical outlet.
9. Plug one end of the grey **short 6-wire** cord into CAM port 1.
10. Plug the other end of the grey **short 6-wire** cord into the wall-mount jack.

11. Align the slots on the back of the phone with the studs on the wall-mount plate.
12. Slide the phone down until it locks into place.

 *The stand is not used when wall mounting your Venture.*

Setting up your phone

Once you have made all the physical connections required and powered up your phone, your display shows:

```
*=English
#=Españ Franc:1
JAN 1 12:00AM
```

1. Press *, # or 1 to select your preferred language.

 *You can change the language at any time by accessing the Options list and selecting a new language under Option 28.*

2. The display now shows:
Enter Phone ID
(01 - 99)
3. Enter a number between 01 and 99 for the phone ID—a different two digit number for each Venture set in your system. The display shows **Please wait** while it confirms that the two-digit number you entered has not been used for another phone. When the phone has finished checking, the display shows **confirmed**.

 *If your display shows Invalid phone ID Please try again instead of confirmed, enter a different phone ID number.*

4. Press **Save**. Your display shows **Enter a name for this Phone**. Use the dial pad to enter a name. See “Entering numbers, letters and symbols” on page 16.

☞ *A name can have up to 16 characters including spaces.*

5. Press **Save** once you have entered a name.
6. Fill out the paper handset label.
7. Insert the handset label on the front of the phone and attach the plastic handset lens.

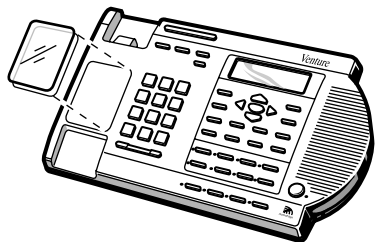

8. Press each line key (to which a telephone line is connected) as well as the I/C key—listen for dial tone. If you don’t hear a dial tone, see “No dial tone” on page 63.

Your Phone list

The phone ID and name of each new phone is automatically added to each Public Directory in the system and forms part of the Phone list. If you have more than one phone in your Venture system, you can use the Phone list to call the other phones in your Venture system. For more information on using lists, see “The Phone list...” on page 52.

Phone list changes

Changes made to a phone ID or phone name are automatically updated on all Phone lists in your Venture system.

If you disconnect a Venture phone to move it to another location, the Venture automatically updates the system and re-establishes communication.

If you permanently remove a phone from the Venture system, you must manually delete the phone ID and name from each Venture set (see “To delete a Phone list entry” on page 55).

Checking the installation

Single phone check

To check the installation of a single Venture TAD, simply press each line key. You should hear a dial tone and each line's indicator should light.

System check

Once each Venture set is installed, you need to ensure that your system is communicating. To do so, you must verify that line 1 is common to each Venture set in your system.

To verify, first lift the handset and press the line 1 key on **ONE** set. You should hear a dial tone and the line 1 indicator should be lit—leave the handset off hook. Next, move to each Venture set in the system. If the line 1 indicator light is lit on all sets, you have successfully installed your Venture system!

You can also press  and enter 00 using the dial pad—all phones in your system should ring.

At each phone, check the following:

1. When idle, press  to review the ID and name of each phone in your system. If you have assigned phone 01 the name “Venture One” and it is not in use, the display shows:
Venture One
Phone 01 idle
If “Venture One” is being used, the word **idle** is replaced by **busy**. If neither idle nor busy shows, see “Communication problems” on page 63.
2. Repeat for each phone in the system.
3. **Reconnect any non-Venture equipment that shares the telephone lines used by your Venture phones.** (This equipment was disconnected before the installation of your Venture phones.)

Entering numbers, letters and symbols

Each dial pad key has a variety of symbols, as well as the labelled number and letters, programmed into it. When you are prompted to enter a name, simply press the appropriate dial pad key until the number, letter or symbol you wish to enter is displayed. If you go past the number, letter or symbol you wish to enter, continue to press the key; it circles back through the list.

Use the ► key to add a space. The first letter of each word (or character appearing after a space) is capitalized.

If a character you wish to enter is on the same key as the last number, letter or symbol you entered, press ►. You can now add a new number, letter or symbol from the same key.

When a letter is capitalized, press ◼ to change to lower case; when lower case, press ◼ to change to upper case.

☞ *Most symbols are not labelled on the dial pad; numbers and letters are.*

The following illustration shows the numbers, letters and symbols found on each dial pad key.

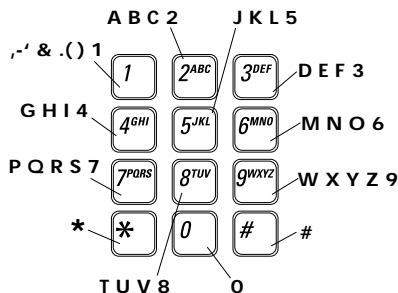

☞ *When entering a number, you may enter up to 24 digits, including pauses.*

☞ *When entering a name, you may enter up to 16 characters., including spaces*

What's next?

At this point you may...



- begin making calls (see “To make a phone call” on page 17).
- program your options, such as Don't disturb or Receive page (see “Options chart” on page 25)
- set up your answering device (see “Setting up your Answering device” beginning on page 35)
- learn more about or program your memory keys (see “Saving to memory keys” on page 48)
- learn more about or program your Venture lists (see “List descriptions” on page 52)

With your Venture phone you can make and receive calls using several different methods. You can also transfer calls, reserve lines and use features while making calls.

Making calls

By setting various options you can customize your Venture TAD to your individual needs. You can decide if you want to set your Venture to predial (the number you enter is not dialed out until you pickup the handset, press a line key or press Handsfree/Mute). This option helps to prevent dialing errors (see Option 13, Live dialpad, on page 28 to turn this option on or off). You can also set your Venture TAD to automatically select an outgoing line (see Option 11, Prime line on page 27).

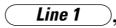
To make a phone call

- Pick up the handset, press , ,  or the Handsfree/Mute key.

- When you hear the dial tone, use the dial pad to enter the phone number you want to call.
- When you complete your call, hang up or press  to end the call.

Joining calls & reserving lines

When you select a line that is already in use, your display shows:

*=Join call #=Reserve line

To join the call

- To join the call in process on that line, press *.

To reserve the line

You may decide that you do not want to join a call but want to use that line as soon as it becomes available.

- Press # to reserve the line. When the reserved line becomes available, your phone beeps and the display shows:
Line x available

- To cancel a reserved line, press the line key you reserved and then press #.

To make an intercom call

An intercom call is a call to another phone in your Venture system.

- Press .
- Use the dial pad to enter the ID number for the Venture phone you want to call.

 *When you cannot complete your intercom call, one of the following three messages appears on your display:*
System busy –no intercom channel is available.
Phone busy –the phone you are trying to reach is busy.
Phone not responding –the phone is not communicating (“Communication problems” on page 63).

Other ways to make a call

Any number stored in a Venture list or to a memory key can also be used to make calls. See “To make a call or activate a feature in a list” beginning on page 54.

Answering calls

If you subscribe to Caller ID or Caller ID on Call Waiting from your local telephone company, your phone displays the name and number of incoming callers (after the first ring and when available) before you answer.

When you subscribe to Caller ID or Caller ID on Call Waiting from your telephone company, you will see different information depending on the service you subscribe to. For example:

Incoming call icons

If you subscribe to Caller ID you will see the following icons.

If you subscribe to Caller ID on Call Waiting and receive a second call, you will see the following icons.

To answer a call

When the phone rings:

1. Pick up the handset, press the Handsfree/Mute, the flashing  or the line key.

 *If more than one incoming call is ringing, your Venture selects your prime line or the line that has been ringing the longest (see Option “12 Answer line” on page 27 for more information).*

To answer an intercom call

You can answer an intercom call in the same manner as a regular call — with one exception. If you have programmed a memory key on your Venture set with the same number as an incoming call, you can also press the flashing memory key to answer the intercom call (see “Saving to memory keys” on page 48 for further information).

Another call—another line

When you are on a call and a second call comes in on another line:

- you will hear a beep but the phone will not ring;
- call announce will not be heard;
- the line indicator light blinks; and
- if you subscribe to the Caller ID or Caller ID on Call Waiting, the ► icon is displayed.

1. Press ► to see information about the second call (that is the name/number if available).
2. If you want to interrupt your current call to answer this new call, press the line key with the flashing indicator light. You are automatically connected to the second call and your first call is automatically placed on hold.

☞ *You can switch back and forth between the two calls by pressing each line key.*

Answering Call Waiting calls

When you subscribe to Call Waiting, you can answer a second incoming call on a line that is already in use. If you subscribe to Caller ID on Call Waiting, you can not only answer the second call but also know who is calling before you answer. When a second call comes in, you will hear the unique Call Waiting tone — press  to interrupt your call. You are automatically connected to the second call and your first call is placed on hold.

☞ *You can switch back and forth between the two calls by pressing .*

Adjusting the receiver and speaker volume

While making or receiving calls, you can adjust the volume of the Handsfree speaker or handset receiver.

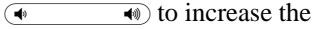
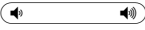

- Press the right side of  to increase the volume level.
- Press the left side of  to reduce the volume level.

☞ *If you want to change the volume of the handset receiver permanently, see Option “14 Hndset deflt” on page 28.*

Adjusting the ringer volume

When the phone is idle or ringing, you can adjust the volume of the ringer.

You need to adjust the volume for each of the three telephone lines.

1. Press .
The display shows:
Ringer volume
Select line key
2. Press a line key.
3. Press the right side of the volume bar to increase volume
OR
press the left side of the volume bar to reduce volume.
4. Press .
5. Repeat for each line.

Using the Handsfree and Mute features during calls

When making or receiving calls you can use the Handsfree speaker and microphone instead of the handset.

When Handsfree is activated you or a number of people can hold a conversation without using the handset. If you need to speak privately or do not wish your caller to hear room noise, you can mute the sound so that your caller cannot hear you.

 ***The Handsfree speaker and receiver work most effectively when set at moderate volume levels.***

To activate Handsfree

1. Press the Handsfree/Mute key to answer an incoming call or to obtain a dial tone. The Handsfree light turns on and you will hear your caller or dial tone through the Handsfree speaker.
2. To end a handsfree call, press .

To activate Mute



While on a handsfree call:

1. Press the Handsfree/Mute key again. The indicator light flashes and the display shows **Microphone muted**. You can still hear the caller but the caller cannot hear you.
2. When you want to be heard by the caller, press the Handsfree/Mute key again. The light stays on to indicate you are still on handsfree.

Transferring calls

You can answer a call and then send (transfer) it to another phone in your Venture system.

To transfer a call

1. When you have answered a call that you want to transfer, press **Transfer**. The display shows Transfer to? .
2. Press  until the display shows the phone to which you want to transfer the call
OR
if you have programmed a memory key for the phone that you want to transfer the call to, press the memory key.
3. Press  (Play) or **Transfer**.

 *If the destination phone is busy or does not answer within four rings, the transferred call rings back to the sending phone and the display shows Transfer back.*

Making conference calls

You can make a conference call that includes any two phone lines or one phone line and another phone in your Venture system.

To make a conference call

1. Make or answer a call.

 *If you press **Conference** without placing your calls first, the display shows:*

Make calls first.

2. Press **Hold**.
3. Make your second call.
4. Press **Conference**.
5. You and the two numbers you dialed may now speak.

 *If you have more than two lines on hold or connected, the display shows Select line key. Press the line keys you want to include in your conference call.*

 *When you hang up or press **Goodbye**, all calls are disconnected.*

To place a conference call on hold

1. Press **Hold**. All the conferenced lines are placed on hold.

 *When a conference call is on hold, the conferees cannot speak to each other.*

2. To reestablish the call, press **Conference**.

 *Remember, only two other callers or lines, along with yourself, can be involved in a conference call.*

 *When you are on a conference call, you cannot use your dial pad to send tones (for example, to use a voice mail system or banking service).*

To consult privately during a conference call

1. Press the line key for the person with whom you want to speak privately. The other line is automatically placed on hold.
2. To reestablish the conference call, press **Conference**.

☞ *If you make a conference call using the telephone service 3 Way Calling, you must use **Flash** to connect each participant to the call.*

Paging

Paging is a feature available only between phones in your Venture system. You can page all phones in the system at once, or a single Venture set.

Paging all phones

1. Hold down **I/C** for two seconds. The page tone is heard on all phones in the system, unless they are in use.
2. Wait for the tone to end.

3. Speak into the handset or handsfree microphone.
4. Hang up or press **Goodbye** to end the page.

Paging one phone

1. Press **▼** repeatedly until the display shows the phone you want to page.
2. Hold down the **I/C** key for two seconds
OR
if you have saved that phone ID to a memory key, hold down the memory key for two seconds.
3. Wait for the tone to end.
4. Speak into the handset or the handsfree microphone.
5. Hang up or press **Goodbye** to end the page.

☞ *You may also program the page option to a memory key (see “To Save an option to a memory key” on page 50).*

To answer a page

When all phones in the system are paged, you will hear two short tones before the person paging you begins speaking. You can listen but you can not respond.

When only your specific phone has been paged, you will hear a tone (at 15 second intervals) until you pick up the phone or press the Handsfree key. If you have Handsfree answer turned on (Option “03 Hndfree ansr” on page 26), you can answer the page by talking into the handsfree microphone without touching your phone.

If you have Option 03 set to off, you must lift the handset or press the Handsfree key to respond.

Setting up Room monitor

The Room monitor feature is used to remotely listen to sounds in a room, such as an unattended lobby or a baby's room. The Room monitor feature only works between two phones at a time. When functioning, each phone's display shows the message: **Room monitor ON**.

If you receive a call when Room monitor is active, you must press the flashing line key to answer the call and press **▶** to view the incoming callers information. **Answering a call turns Room monitor off on both phones.** If your TAD answers the call, Room monitor remains activated.

You must first program a memory key with the room monitor option (see Option "08 Memory keys prog" on page 26) for every Venture set.

Saving Room monitor to a memory key

1. Press **Options**.
2. Press **▼** until the display shows: **08 Memory keys prog**.
3. Press *****. The display shows: **Don't disturb**.
4. Press **▼** until the display shows: **Room monitor**.
5. Press *****. The display shows: **Press memory key**.
6. Press the memory key you want to use for the Room monitor feature. The display shows: **Saved: Memory key Room monitor**.
7. Note on the memory key label which key you have used for Room monitor.
8. Repeat steps 1 through 7 on every Venture set from which you may wish to monitor.

Setting the Room monitor option

On the set you wish to listen to, you must set Option "07 Room monitor" on page 26 to on. If this option is not set to on, the Room monitor option is not available.

1. Press **Options**.
2. Press **▼** until the display shows: **07 Room monitor OFF**.
3. Press *****. The display shows: **Room monitor ON**.

To activate Room monitor

1. Go to the phone from which you wish to listen (monitoring phone).
2. Press **▼** until the display shows the ID of the phone you want to monitor.

3. Press the Room monitor memory key, you programmed previously, in the room which you wish to listen from. The light next to your Handsfree key flashes and your display shows: Room monitor ON.

☞ ***Find the Phone ID for the phone you wish to monitor and press the Room monitor memory key to begin monitoring from a new location.***

To end Room monitoring

1. When the display shows: Room monitor ON
 2. Press Goodbye.
- ☞ ***Answering a call turns Room monitor off on both phones. If your TAD answers the call, Room monitor remains activated***

Using a headset

You can connect a headset and amplifier for your Venture phone. This enables you to make and answer calls without using the handset.



When Option “05 Headset” on page 26 is set to on, your handsfree functionality is disabled. Once connected and set up, simply make or answer calls by pressing the Handsfree/Mute key and talking/hearing using the Headset. Press Goodbye to disconnect calls.

If you wish to return to Handsfree operation, you must reset Option 05 to Headset off.

☞ ***An amplifier is recommended. It allows you to keep both your headset and handset connected to your Venture. Simply switch between headset and handset to customize your Venture.***

Your Venture phone comes equipped with the most commonly used options already set for you (default settings). As you begin using your phone you may decide to change the way your phone operates. You can do this by customizing any of the 42 available options to suit your individual needs.

To set an option

1. Press .
2. Press  or  repeatedly until your display shows the option you want to set
OR
use the dial pad to enter the two digit option number to go directly to it in the list (e.g. 06 for Call timer).
3. Follow the display prompts to select the setting you prefer.

The following chart explains each option. Options are listed in the order in which they appear in the list. The first column shows the option number and name. Enter this number to go directly to it in the list — no need to scroll through the list. The second column shows the possible settings for each option. An asterisk (*) indicates the default setting of an option. The last column explains how the settings for each option affects the way your phone works.

Options chart

Number and Option	Settings (*=default)	Option function
01 Don't disturb	OFF* ON	Allows the phone to ring for internal and external calls. Prevents the phone from ringing for external and internal calls nor will you hear a page or call announce. The multipurpose light still flashes for incoming calls from outside your Venture system.
02 Receive Page	ON * OFF	Allows the phone to receive pages. Prevents the phone from receiving pages.

Options chart

Number and Option	Settings (*=default)	Option function
03 Hndfree ansr	ON * OFF	Allows you to answer a page automatically, without lifting the handset or pressing the Handsfree/Mute key. You will hear a page tone every 15 seconds. Allows you to answer the page by lifting the handset or by pressing the Handsfree/Mute key or I/C key. You will not hear a page tone.
04 Contrast	level 4 * (levels 1 - 8)	Increases or decreases the contrast from 1 (the lightest) to 8 (the darkest) to better view the display.
05 Headset	ON OFF*	Allows you to make or answer calls using a headset plugged into the handset port on the back of the phone when you press the Handsfree key. Prevents headset use (must use the handset or Handsfree key). See "Using a headset" on page 24.
06 Call timer	OFF* ON	Turns off the Call timer. During active calls, the elapsed time of the call is displayed on the third line of the screen.
07 Room monitor	OFF* ON	Prevents your phone from being monitored by another Venture phone in your system. Enables your phone to be monitored by another phone in your Venture system.
08 Memory keys Prog		Allows you to program the Venture options: Don't disturb; Page; Room monitor; or Call timer to any of the memory keys. For additional information, see "To Save an option to a memory key" on page 50.

Options chart

Number and Option	Settings (*=default)	Option function
09 Secure number		<p>When you secure a number, passwords such as PINs and access codes are replaced with asterisks (*) so the password will not be visible on your display. You can secure up to five 12-digit numbers.</p> <p>For example, your bank PIN is 3333 and your bank phone number is 555-4444. When 555-4444 is made a secure number and you dial this number, the display shows 555-4444. When you then enter your PIN (3333), the display shows ***** instead of 3333. This ensures your security.</p>
10 Clear Msg. Wtg.		<p>If you subscribe to the telephone service voice messaging, and the Message waiting prompt and telephone light remain on after you have retrieved your messages, use this option to turn the prompt and light off. If this does not work, see “You can’t turn off the message waiting light” on page 66.</p>
11 Prime is	Line 1 * (Line 2 or 3) No Prime line	<p>Allows a line to be automatically selected each time you pick up the handset or press the Handsfree/Mute key. You can select line 1, 2 or 3 for your Prime line.</p> <p>Prevents automatic selection of a Prime line. You will have to manually select a line to make or answer a call.</p>
12 Answer line	Answer Prime Answer Longest*	<p>The Prime line is automatically selected when more than one line is ringing at the same time and you pick up the handset or press Handsfree without selecting a line.</p> <p>The line that has been ringing the longest is automatically answered when more than one line is ringing at the same time.</p>

Options chart

Number and Option	Settings (*=default)	Option function
13 Live dialpad	ON OFF*	Numbers entered using the dial pad are automatically dialed out on the defined Prime line. If no Prime line is set in option 11, you are prompted to press a line key. Numbers entered using the dial pad are displayed before dialing. You must manually select a line to make the call.
14 Hndset deflt	ON * OFF	When you change your phone's handset volume while you are on a call, the change lasts for the duration of that call only. When you change your phone's handset volume while you are on a call, the volume change is permanently saved.
15 Callers log	All calls* Unanswered calls No calls	All incoming calls are logged in the Callers list.* Only unanswered incoming calls are logged in the Callers list.* No incoming calls are logged in the Callers list. (Set this option for each line on your phone.)
16 Repeat caller	Combine calls * Separate calls	Only one Callers list entry is created for all calls from that number (when no message is left); a count of the number of times that number called is displayed (up to 9x).* When a message is left, calls are not combined but logged separately. Caller information is listed separately in the Callers list, regardless of how many times the same number called.*
17 Area codes		Prevents selected area codes from being shown in your Callers list. Useful in locations where area codes cannot be used to make local calls. Area codes are displayed in parentheses in the Callers list. Enter up to three 3- to 7-digit codes.

* You may be required to subscribe to Caller ID or Caller ID on Call Waiting from your local telephone company.

Options chart

Number and Option	Settings (*=default)	Option function
18 Restrictions		Blocks specific numbers or numbers beginning with certain digits (such as long-distance calls starting with 0 or 1) from being dialed from your phone. You can restrict up to five 12-digit numbers.
19 Overrides		Allows numbers that have been restricted (Option 18) to be dialed from your phone. For example, if you have restricted long-distance calls beginning with 1 or 0 from being dialed, you can allow 1-800 calls to be made. You can override up to five 12-digit numbers.
20 Ring tone	4* (telephone lines) 1* (intercom line) (1,2,3,4)	Enables you to select one of four styles of rings for <i>each</i> telephone line and intercom line on your phone.
21 Password		Enter a one-, two-, three- or four-digit password to allow the Options list to be viewed or modified. To remove a password, use the delete key. If you forget your password, see "You forgot your password" on page 65.
22 Lock lists	ON OFF*	Disables the save, delete and change keys so that no one can change or delete the contents of a list or memory key. You can still erase all items in a Directory using Option 25. Allows the contents of a list or memory key to be changed or deleted.
23 Phone ID		Allows you to change the two-digit number used to identify your phone to the system.
24 Phone name		Enables you to change the name used to identify a Venture phone in the Phone list.

Options chart

Number and Option	Settings (* = default)	Option function
25 Directory		Enables you to erase all items in either the Public Directory or one of the three Private Directories. This can be done even when Option 22, Lock lists is on.
26 Reset options		Resets all the options on your phone to the default factory settings.
27 Time/Date		Enables you to manually set the time and date. Your first incoming call resets the time and date.*
28 Language choice	English* French, Spanish	Changes the language used on the display to English, French or Spanish.
29 Versions		Displays the software versions used by your phone. This information may be necessary when calling your telephone company for assistance.
30 System test	Key test LCD test LED test	When each key is pressed, this test displays a number to indicate that the key is functioning. Fifteen seconds after you stop pressing keys, this test automatically ends. The display is filled to show that each information display area is functioning. Illuminates the lights on the phone to show that they are working.
31 Answer machine	ON* OFF	Turns the answering device on. (Will still answer after 15 rings so that Remote access is still possible even when this option is off.) Turns the answering device off.

* You may be required to subscribe to Caller ID or Caller ID on Call Waiting from your local telephone company.

Options chart

Number and Option	Settings (*=default)	Option function
32 Auto attend	ON OFF*	Creates an auto-attendant service (see “Setting up Auto Attendant” on page 40). Allows normal Answering Device functionality.
33 Block Priv. #	ON OFF*	Sends incoming calls, with blocked names and/or numbers, directly to the Private mailbox after the first ring. You need to record a greeting, indicating that you do not accept calls from blocked numbers and to leave a message if they want the call returned. (Programmed for each line.) Calls from telephone numbers that have been blocked are treated like all other incoming calls.
34 Callannounce	Name or number Name only Announce off*	Matches incoming calls to the name or number you entered in your Directory and plays the voice tag you recorded when you entered the number and name. If no match is made or voice tag recorded, the phone number is announced.* Matches to the name you entered in your Directory and plays the voice tag you recorded. If no match is made or voice tag recorded, no announcement is made for incoming calls.* No announcement is made for incoming calls.*
35 Mess. alert	ON OFF*	Activates an audible alert to notify you when there are new messages. Disables the audible alert.
36 Msg. length	2 minutes* (1 – 8 minutes)	Allows you to program the maximum message or greeting length.

* You may be required to subscribe to Caller ID or Caller ID on Call Waiting from your local telephone company.

Options chart

Number and Option	Settings (*=default)	Option function
37 No. of rings	4 rings* (1 - 9 rings)	Sets the number of times your phone rings before the telephone answering device answers a call.
38 RemoteNotify	ON OFF*	When a message is received, your phone calls you (at the number you specify in Option 40) to indicate you have new messages. You are required to enter a password (see Option 39) to hear messages. Prevents remote notification, even if you have the feature turned on, for a particular mailbox.
39 Remote password	2222* (any 4-digit number)	Changes the default Remote password (2222) to any four-digit number you choose. This password must be used to access your phone messages and features from another phone.
40 Remote Phone#		Enter the telephone number that you want called when you have a new message. The number may be no longer than 18 digits.
41 Screen calls	ON OFF*	Allows you to hear messages over the handsfree speaker while they are being recorded. You may still answer a call while a message is recording. Prevents messages from being heard while recording.
42 Toll saver	ON OFF*	Incomings calls are answered after the second ring when you have NEW messages. When there are no new messages, the phone will ring the number of times you specified in Option 37. Use this option to save toll charges when retrieving messages remotely. The phone rings the number of times you specified in Option 37 before your telephone answers.

The Venture 3-Line Telephone with Answering Device (TAD) answers calls that you are unable or choose not to answer. The versatility of the built-in answering machine allows you to customize your Venture and makes retrieving and sorting messages easy.

☞ *The total recording time is approximately 60 minutes.*

Answering Device Basics

You hear...

messages - recorded by an incoming caller when you do not answer their call.

voice tags - recordings you make, when entering numbers and names in the Directory, to announce the name of the incoming caller.

mailbox tags - heard when you call your Venture from a remote site to retrieve messages. Some tags are prerecorded, others you need to record.

memos - recordings you make for someone to play back on the Venture set you recorded the message on.

Callers hear...

greetings - recorded by you for incoming callers to hear when you do not answer their call.

The Venture allows you to record a general greeting or specific greetings for each entry in your Directory and also record specific greetings for its various mailboxes.

Example:

General - “Hi! No one is available, please leave a message.” Everyone will hear this greeting.

Specific - “Hi Mom! Leave a message, I’ll call back shortly.” Only someone calling from “Mom’s” telephone number will hear this greeting.

Mailboxes

Mailboxes are predefined areas where messages can be stored.

Special mailbox - used for calls with the Distinctive Ring tone (subscription required).

Private mailbox - used when an incoming call is from a blocked or private telephone number, enabling you to screen calls.

Mailboxes for lines 1, 2 and 3 - organizes and stores incoming messages for each separate line.

Nine customizable mailboxes - organizes and stores incoming messages as you choose.

Mailboxes can be set up to:

- provide information to callers through specific greetings
- greet callers and allow them to leave messages in different mailboxes
- take messages from two lines at the same time
- ring-through to speak to a person.

☞ ***Mailboxes are not password protected. Messages are accessible to all Venture system users.***

☞ ***Your Venture TAD can record a message for 2 lines at once. If a third call is received, it will go unanswered.***

You can use the factory recorded greeting for calls, or:

- record one greeting for all calls (General Greeting)
- record separate greetings for all 14 mailboxes
- record a personal greeting for any of the numbers entered in your Directory.

In addition, you can:

- use the Auto Attendant feature to provide information to and take messages from callers
- retrieve your messages from remote locations

- have your phone notify you when you are at a remote location that you have messages

See “Mailbox greetings and mailbox tags” beginning on page 36 and “Mailboxes and Directory entries” beginning on page 56 for further information.

Mailbox Types

Mailboxes 1 through 9 have the following type settings available. See “Selecting a mailbox type” on page 37 for instructions and “Setting up Auto Attendant” beginning on page 40 for an example of when to use a mailbox type.

Announce only - plays the recorded greeting but does not allow a message to be left. Once set, the Greetings list shows: **TYPE announce**.

Normal - plays a greeting and takes messages. Once set, the Greetings list shows: **TYPE normal**.

Ring through - attempts to reach a person by ringing 4 more times. If the call is not answered, the caller is directed to a mailbox to leave a message. Once set, the Greetings list shows: **TYPE ring**. The Ring through type is normally set only when using the Auto Attendant feature (see “Setting up Auto Attendant” beginning on page 40).

☞ ***You may not change the type for the Special mailbox. The Private mailbox and Lines 1, 2 and 3 mailboxes do not have the Ring through type setting.***

Setting up your Answering device

To set the number of rings

You can set your Venture TAD to answer after a predefined number of rings.

1. Press **Options**.
2. Press 37 to go to **No. of rings**.
3. Press *.
4. Enter the number of rings you wish. You must enter at least 2 and not more than 9 rings.
5. Press **Save**.

 *Also see “37 No. of rings” on page 32.*

 *The Answering device is set to On (default). To turn off the answering device, see “31 Answr machne” on page 30.*

Viewing the Greetings list

Press the **Greetings** key to view the Venture’s list of greetings. They appear in the list as follows:

- General Greeting
- Private Mailbox*
- Mailbox 1 through Mailbox 9
- Special Mailbox*
- Line 1, 2 and 3 Mailboxes

*You may be required to subscribe to a telephone company service in order to use these TAD features.





In the Greetings list you can change:

- mailbox name
- mailbox greeting
- mailbox tag
- mailbox type
- set remote notification

Press the **Change** key and follow the instructions on the display.

Recording a General greeting

If you do not record specific mailbox greetings or Directory greetings, the General greeting will be heard for all lines and mailboxes. If recorded, the Private and Special greetings play in place of the General greeting when incoming calls meet those mailbox requirements.

1. Press **Greetings**. Display shows: **Greetings list**
Use ,  to view
2. Press . The display shows: **General greeting**
=Next * = Change
3. Press *. The display shows. **Lift Handset to record greeting**
4. Lift the handset. The display shows:
Press RECORD to begin
For the best quality recording, speak into the handset.

- Press **Record**. The display shows:
Recording...
Use **SAVE** to end
- Press **Save** when you have finished recording your greeting.

☞ *To review your greeting press **Play**.*

☞ *Modify a General greeting by repeating the steps above (record a new greeting over the old).*

Changing a mailbox name

Mailbox names can be up to 10 characters long including spaces.

- Press **Greetings**. The display shows:
Greetings list
Use **Left Arrow**, **Right Arrow** to view
- Press **Right Arrow** until the display shows the mailbox you want.
- Press **Change**. The display shows the mailbox name as follows:

Mailbox x
Next **Change**

☞ *The names of the General, Special and Private greetings cannot be changed. The display only shows **Next**, indicating you should move to the next selection.*

- Press *****. The display shows:
Press 1st letter to enter name
- Use the dial pad keys to enter the name (see “Entering numbers, letters and symbols” on page 16).
- Press **Save**.

Mailbox greetings and mailbox tags

A mailbox greeting provides information to incoming callers. You can record a specific greeting for a specific mailbox. You can then direct calls automatically to that mailbox.

A mailbox tag is what you hear when you call your Venture set from a remote site. Mailbox tags are prerecorded for all available remote functions. However, when you change the name of a mailbox, you should record a new mailbox tag.

Recording a mailbox greeting or tag

- Press **Greetings**. The display shows:
Greetings list
Use **Left Arrow**, **Right Arrow** to view
- Press **Right Arrow** until the display shows the mailbox you want.
- Press **Record**. The display shows:
***=Greeting**
#=Mailbox tag
- Press ***** or **#**. The display shows:
Lift Handset to record greeting or record voice tag

5. Lift the handset. The display shows:
Press RECORD
to begin
6. Press **Record**. The display shows:
Recording...
Use SAVE to end
7. Record your message.
8. Press **Save**. The display shows:
Saved greeting or
Saved tag
Time left xx:xx

Reviewing a mailbox greeting or tag

1. Press **Greetings**. The display shows:
Greetings list
Use , to view
2. Press until the display shows the mailbox you want.

3. Press (**Play**). The display shows:
*=Greeting
#=Mailbox tag
4. Press *. Your display shows:
Playing greeting or
press #. The display shows:
Playing Mbox tag

Selecting a mailbox type

There are three types of mailboxes:

- **Normal** — plays a greeting and takes messages.
- **Announce only** — plays a greeting; no opportunity to leave a message.
- **Ring through** — provides the opportunity to speak to a person before leaving a message. Normally used only when setting the Auto Attendant feature (see “Setting up Auto Attendant” on page 40).

To select a mailbox type

1. Press **Greetings**.
The display shows:
Greetings list
Use , to view
2. Press until the display shows the mailbox you want.
3. Press **Change**.
4. Press until the display shows:
TYPE xxxxxxxx
=Next *=Change
 The Special mailbox type cannot be changed.
5. Press *. The display shows:
TYPE xxxxxxxx
=Next SAVE=End
6. Press until you see the type you want.
7. Press **Save**. The display shows:
Saved Mbox type
TYPE xxxxxxxx

Deleting or changing a mailbox greeting or tag

1. Press **Greetings**.
The display shows:
Greetings list
Use **▲**, **▼** to view
2. Press **▼** until the display shows the mailbox you want.
3. Press **Change**. The display shows the name of the mailbox and **▼=Next *|=Change**.
4. Press **▼** until the display shows Mailbox Greeting or Mailbox tag.
5. Press * to change and record a new greeting or tag OR press **Delete** twice.
6. If deleted, the display shows:
Item is erased
Time left xx:xx

☞ When you delete a line, special or private greeting, your TAD will default to the General greeting. If you delete a General greeting, you will default to the original factory

recorded greeting. A greeting is therefore always available.

☞ See “To Save to a Directory” on page 56 to select a mailbox when creating a new Directory entry.

☞ See “To assign a mailbox to an existing Directory entry” on page 57.

Personal greetings and voice tags

You can record a personal greeting and voice tag for all entries in your Directory.

In order to hear personal greetings and tags, incoming calls must be received from the telephone number entered in your Directory (you may be required to subscribe to Caller ID or Caller ID on Call Waiting).

Callers hear...

- A personal greeting such as, “Hi Peter. The time for the marketing meeting is 2:30. See you there!”. (The incoming call must be from the number entered in your Venture Directory.)

You hear...

- A voice tag, such as “It’s Peter calling” over the speaker each time the person calls. (The incoming call must be from the number entered in your Venture Directory.) Option 34 must be set to Name or Number or Name only to play voice tags (see page 31).

To record a personalized greeting or voice tag

1. Press **Directory**.
2. Press **◀** or **▶** until the display shows the sub-directory you want.
3. Press **▼** until the display shows the Directory name or number you want.
4. Press **Record**.
5. The display shows:
*=Greeting
#=Voice tag
6. Press * or #. The display shows:
Lift Handset to
record greeting or
record voice tag

7. Lift the handset.
The display shows:
Press RECORD
to begin
8. Press **Record**.
The display shows:
Recording...
Use SAVE to end
9. Record your greeting or voice tag.
10. Press **Save**.
The display shows:
Saved: greeting or
Saved: tag
Time left xx:xx

To listen to a personalized greeting or voice tag

1. Press **Directory**.
2. Press ◀ or ▶ until the display shows the sub-directory you want.
3. Press ◼ until the display shows the Directory name or number you want.

4. Press **Greetings**. The display shows:
*=Greeting
#=Voice tag
5. Press * or #.
The display shows:
Playing greeting
OR
Playing tag
It is played through the handsfree speaker.

 *To listen to the greeting or voice tag through the handset, lift the handset while the message is playing. If you lift the handset before the message begins, the number you have selected is dialed.*

To change a personalized greeting or voice tag

To change a personalized greeting or voice tag, record over the existing greeting or tag. See “To record a personalized greeting or voice tag” on page 38.

To delete a personalized greeting or voice tag

1. Press **Directory**.
2. Press ◀ or ▶ until the display shows the sub-directory you want.
3. Press ◼ until the display shows the name/number you want.
4. Press **Greetings**.
The display shows:
*=Greeting
#=Voice tag
5. Press * or #.
6. While playing, press **Delete** twice.
The display shows:
Greeting or Voice tag
erased
Time left xx:xx

Setting up Auto Attendant

When Option 32, Auto Attend is set to On, your Venture TAD answers incoming calls and directs them to any mailboxes you specify.

You must record a General greeting, which directs callers to select a number to leave a message in a specific mailbox (1 through 9); record a greeting for each mailbox you specified in your General greeting; and set the mailbox type for each mailbox (see“Mailbox Types” on page 34 for further information).

Example:

Record a General greeting such as, “This is ABC Company. Press 1 for hours of business, press 2 to leave a message, press 3 to speak with our accounts manager.” All incoming callers will hear this General greeting.

You would also record a specific greeting for each mailbox specified in the General greeting (mailbox 1, 2 and 3) and set each mailbox type as follows:

Mailbox 1 - record a greeting listing the business hours and set the mailbox type to “announce only”.

Mailbox 2 - record a greeting encouraging callers to leave messages and set the mailbox type to “normal”.

Mailbox 3 - record a greeting stating that the accounts manager is unavailable and a message should be left; set the mailbox type to “ring through”.

To set up Auto Attendant

- 1 Turn on Auto Attendant Option 32.
- 2 Record your General greeting, noting the mailbox numbers and their subject.

- 3 Record each mailbox greeting, ensuring the mailbox numbers and subjects match those stated in the General greeting.

- 4 Set the mailbox type (see“Mailbox Types” on page 34 for further information).

To turn on Auto Attendant

1. Press **Options**.
2. Enter 32 on your dial pad. The display shows:
Auto attend OFF
☐=Next. *=Change
3. Press *. The display shows:
Auto attend ON
-confirmed-

To record your Auto Attendant greeting





To use the Auto Attendant feature, think of your Auto Attendant greeting as the General greeting. See “Recording a General greeting” on page 35.

Ensure that you make note of each mailbox number and its subject. You will need this information when recording the individual mailbox greetings.

 ***When Auto Attendant is active, personalized greetings can no longer be heard.***

To set up Auto Attendant



Refer to your list of mailbox numbers and subjects, as recorded for the General/Auto Attendant greeting.

1. Press . The display shows:
Greetings list
Use ,  to view
2. Press  until the display shows the assignable mailbox you want (1 through 9).
3. If you wish, enter a name for the mailbox. See “Changing a mailbox name” on page 36.
4. Record a greeting. See “Recording a General greeting” on page 35.
5. Set the mailbox type to Announce only, Normal or Ring through, depending on how you want the mailbox to work. See “Selecting a mailbox type” on page 37.
6. Record a new mailbox tag. See “Mailbox greetings and mailbox tags” on page 36.
7. Repeat for each mailbox mentioned in the General/Auto Attendant greeting.

Receiving a voice message

When the Telephone Answering Device (TAD) answers a call, the first line of your display shows the number of the line being answered.

The third line shows , which means the TAD is recording a new message. In addition, the line key indicator light for the line receiving the call flashes slowly.

You can be using one line while the TAD records messages received on Venture’s two other lines. When you subscribe to Caller ID on Call Waiting and a second call is answered by the TAD, the display shows . Press the  key to see the caller information for the second call.

You can limit the maximum length of an incoming message using Option “36 Msg. length” on page 31.

Knowing when you have a message

After the TAD has answered a call, the telephone indicator light will flash slowly and **x New messages** appears on the screen.

Message Alert

You can program your phone to alert you audibly when there is a message or a memo. A reminder tone sounds every 20 seconds. The default setting for the message alert is off.

1. Press **Options**.
2. Using the dial pad enter 35.
The display shows:
Mess. alert OFF
3. Press *. The display shows:
Mess. alert ON
- confirmed -

Listening to your messages

You can listen to new messages or old messages. You can also listen to messages from specific mailboxes or individual messages. Use **(Play)** to play new and old messages; use

Callers to listen to specific mailbox or individual messages.

New and old messages are played in the order they were received.

Message playback controls

You can control message playback by using the following keys while a message is playing:

- **◀** — skips back two seconds in the message and resume the playback.
- **Hold** — pauses the message. (Press **Hold** again to resume playback.)
- **(Play)** — starts the message from the beginning.
- **Delete** — deletes the message.

To listen to your new messages

1. Press **(Play)**.
The display shows:
Choose mailbox
or **PLAY for all**
2. Press **(Play)** again to listen to all your new messages. If you do not have any new messages, all your old messages are played.
 - Your new messages are played in the order they were received with a short tone between each.
 - To listen to your messages privately, lift the handset once you have pressed **(Play)**.

To listen to old messages

1. When you have no new messages, press **(Play)** twice. All messages are played in the order they were received with a short tone between each.

To listen to mailbox messages

Access mailbox and individual messages through the Callers list.

1. Press **Callers**.
2. Press **▶** until the display shows the line or mailbox you want.
3. Press **●** (Play).
4. All of the new messages in the line or mailbox are played.
5. To playback all messages (old and new), press **●** (Play) again.

To listen to individual messages

1. Press **Callers**.
2. Press **▶** until the display shows the line or mailbox you want.
3. Press **▼** to find the message you want.
4. Press **●** (Play) to listen to the message.

To make a message new

Once you have listened to a message, you can make it appear “new” again by reactivating any message alerts, such as tones and lights.

1. Press **Callers**.
2. Press **▶** until the display shows the line or mailbox you want.
3. Press **▼** until the message you want to make new appears.
4. Press *****.

Deleting messages

You can delete messages as you listen to them, delete messages one at a time from the Callers list, delete all messages in a mailbox or delete all messages from all mailboxes and lists.

To delete messages one at a time

You must delete the Callers list entry in order to delete a message. This removes the entire entry from the list.

1. Press **Callers**.
2. Press **▶** until the display shows the required line or mailbox.
3. Use **▼** or **▲** to find the message you want to delete.
4. Press **Delete** twice.

To delete all messages in a mailbox

1. Press **Callers**.
2. Press **▶** until the display shows the required line or mailbox.
3. Press **Delete** twice.

To delete all messages

When you delete the Callers list, you **not only delete all of your voice messages but all entries in the Callers list as well.**

1. Press **Callers**.
2. Press **Delete** when the display shows:
Callers List=x

Recording a memo

Recording a memo allows you to leave a message for someone on your phone.

To Record a memo

1. Press **Record**.
2. Lift the handset. The display shows:
Press RECORD to begin
3. Press **Record**. The display shows:
Recording...
Use SAVE to end
4. Record your memo.

5. Press **Save**. The display shows:
Saving...
Time left xx:xx
THEN
PLAY to review
or SAVE to end
6. Press **Play** to review your memo. The display shows:
Playing memo
THEN
PLAY to review
or SAVE to end

 *If you want to change your memo, press **Goodbye** and start over.*

7. Press **Save**. The display shows:
Saving
Time left xx:xx
8. Select a mailbox as follows:
 - **Save** to automatically save to the General mailbox
 - 1 through 9 for a numbered mailbox
 - line keys 1 through 3 for each line mailbox

- 0 for the Private mailbox
 - # for the Special mailbox.
The display shows:
Saving...
Time left xx:xx
9. Press **Save**.

Locate, listen to, delete and make memos new

You can locate, listen, delete and make memos new just as you do messages.

Remote notification

You can program your Venture phone to call you at a different telephone number when a new message is recorded. If the Remote notification call is not answered, the phone attempts to call you once more (3 1/2 minutes later). **Options 38 and 40 must be set** (see “38 RemoteNotify” on page 32, and “40 Remote phone#” on page 32).

You can also turn Remote notification on for individual mailboxes. Only if a message is left in the particular mailbox are you called. Option 38 must be set to on (see “38 RemoteNotify” on page 32).

To turn the Remote notification option on or off

1. Press **Options**.
2. Enter 38 using the dial pad keys.
The display shows:
RemoteNotify OFF
3. Press *.

 *You can turn Remote notification on or off from a remote phone. See “Remote access” on page 46 and “Changing your Remote access password” on page 46.*

To set the remote notification number

1. Press **Options**.
2. Enter 40 using the dial pad keys.
The display shows:
Remote phone #
☐ = Next * = Enter
3. Press *.
4. Using the dial pad enter the remote notification telephone number and press **Save**.

 *If you want to call a pager system, you may need to insert one or more pauses between the pager number and the number to be paged. Each time you press **Hold** you insert a two second pause.*

5. The display shows:
- confirmed -

Setting Remote notify for individual mailboxes

You can set individual mailboxes to notify you when you have a message. Option “38 RemoteNotify” on page 32 must be set to on.

1. Press **Greetings**. The display shows:
Greetings list
Use ☐, ☐ to view
2. Press ☐ until the display shows the mailbox you want.
3. Press **Change**.
4. Press ☐ until the display shows:
Remote notify ON.
5. If you want to turn remote notify off, press *. The display shows:
Remote notify OFF.

To turn Remote notify off during notification

When you are prompted to enter # to turn Remote notify off, entering # will turn Remote notify off for all calls (turns Option 38 off).

Remote access

You can access your Callers list, Directory, Greetings list, Options list and record memos remotely. Once you've called your Venture set, audible prompts guide you through the various functions.

If you have changed the name of a mailbox and recorded a new mailbox tag, you will hear the new mailbox tag.

When you access your Venture TAD to retrieve messages, you will know if you have new messages: the phone will only ring twice. See the Option "42 Toll saver" on page 32 for further information.

☞ *If you turn your answering device off (page 30), your Venture will still answer after 15 rings. This will allow you to turn on your answering device from a remote location.*

Changing your Remote access password

1. Press .
2. Enter 39 for the remote password.
The display shows:
39 Remote Password
▼=Next * =Enter
3. Use ◀ to back over any existing password (the default is 2222).
4. Use the dial pad to enter your new password. You may use any combination of 4 numbers.
5. Press * to save your new password.

☞ *Also see Option "39 Remote password" on page 32.*

To access your Venture from a remote location

1. Dial the telephone number of your Venture phone.
2. During the greeting press *.
3. Use the dial pad to enter your password.
4. Listen and follow the prompts.

Remote access prompts

- Press 1 to access your Callers list's main menu
- Press 2 to access your Directory
- Press 3 to access your Greetings
- Press 4 to access your Options
- Press 5 to record a memo
- Press * to exit Remote access when in the main menu or use to move back a level when in a list

Once in the Callers list:

- Press 1 to replay
- Press 2 to renew a caller (make new)

- Press # to play time/date for voice messages or calls
- Press 4 to delete
- Press 7 or 9 to scroll through the list of available mailboxes (act as ⏪ keys)
- Press * to return to main menu

Once in the Directory:

- Press 5 or 8 to move up and down through lists (act as ⬆️ ⬇️ keys)
- Press 1 to replay
- Press 4 to record a greeting and press # to save
- Press 6 to play Directory greeting
- Press * to return to main menu

Once in the Greetings list:

- Press 1 to replay
- Press 5 or 8 to move up and down through lists (act as ⬆️ ⬇️ keys)
- Press 4 to record a greeting and press # to save
- Press * to return to main menu

Once in the Options list:

- Press 4 to turn the following Options on or off: Answering device, Toll saver, Remote notification, Remote notification number
- Press * to return to main menu

To record a memo:

- Press 5 to record a memo
- Press # to save and return to main menu

Audible prompts guide you throughout your remote call.

👉 *You must use at least two different lines on your Venture to retrieve messages between phones in your system.*

👉 *You cannot use the intercom to retrieve messages.*

Your Venture phone has eight memory keys which you can customize for easy dialing or option activation.

- 1 Store any telephone number you wish, whether it's already stored elsewhere in your Venture set or not.
- 2 Store the name and Phone ID of the other Venture sets in your system (one ID for each key).
- 3 Program a telephone company service, such as Repeat Dial, Call Forward, or Call Trace.* This will allow you to activate that service by simply pressing a single key and dialing.
- 4 Store the Venture options Don't disturb, Page, Room monitor and Call timer on any of the eight memory keys (Option 08 must be used to save options).

* Contact your local telephone company regarding specific services and charges.

 **Telephone numbers and features are dialed; options are activated.**

Saving to memory keys

You can follow the same basic steps to save, change, delete, dial and activate a telephone number, Phone ID, Telephone Company Feature, or Option.

To Save a Number to a memory key

If you want to save a telephone number not stored elsewhere in your Venture system, follow these instructions.

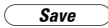
1. Press . Your display will show **Save to?**



 **If your display shows Memory is locked, see option "22 Lock lists" on page 29.**

2. Press a memory key. Your display shows **Enter number.**

3. Enter a number using the dial pad.

 **To insert a two-second pause in the dialing sequence press**

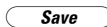
.

4. Press . The display shows:
Press 1st letter to enter name.
5. Use the dial pad to enter a name (see "Entering numbers, letters and symbols" on page 16).
6. Press .

To Save a Number from a list to a memory key

You can save a number from your Callers list (incoming call log), Redial list (outgoing call log), Directory (stored names and numbers) or Services list (telephone company services) directly to a memory key. Simply locate the number in one of Venture's lists (see "To view a list item" on page 54), and follow the instructions "To Save a Number to a memory key" on page 48. If a name is not already entered, you may be prompted to enter a name. Remember to note the name on the memory key paper label for future reference.

Some telephone company services have two codes—one to turn the feature on and one to turn the feature off. You must save each code to a separate memory key (see "To turn a feature and light on or off" on page 59 for specific information).

Saving a Phone ID to a memory key

Press  to locate the list of phone IDs. When you save all the Phone IDs in your system to the memory keys, you will not only be able to quickly dial others in your system, but also display the status of each—a solid light beside a memory key indicates that the phone is in use.

Saving an option to a memory key

You can save the Don't disturb, Page, Room monitor or Call timer options to a memory key. This will enable you to easily activate the option by pressing a single memory key. When any of these options are saved to a memory key, the light beside it will light when the particular feature is activated. You must save these options using Option 08 (see "08 Memory keys prog" on page 26).

Once saved to a memory key, press the...

Don't disturb memory key - (toggles between on/off) prevents all incoming calls from ringing your Venture set (the line light will still flash).

Page memory key - initiates a page call to all Venture sets in your system.

Room monitor memory key - begins monitoring the noise from another Venture set.

Call timer memory key - when in the Redial list or during a call, toggles between the current time and date and the elapsed time of the call or Redial list entry.

To Save an option to a memory key

1. Press **Options**.
2. Enter 08 using the dial pad.
The display shows:
Memory keys prog
3. Press * to enter the selection list.
4. Press **▼** to move through the list: Don't disturb; Room monitor; Page; and Timer.
5. Press * to save one of the four options when it appears on your display. The display shows:
Press memory key.
6. Press the memory key you want to use for the option. The display will show **Saved: Memory key** and the name of the option you saved.
7. Note the name of the option on the memory key paper label for future reference.

To change a memory key

1. Press the memory key.
2. Press **Change**.
 **If your display shows Key is locked, see option "22 Lock lists" on page 29.**
3. You are prompted to first make changes to the number. If you do not wish to change the number press s. You will now be prompted to change the name.
4. Use **◀** to backspace over the numbers or letters you want to change.
5. Press **Save** to confirm your changes.

To delete a memory key

1. Press the memory key.
2. Press **Delete** twice.
 **You cannot delete an option saved to a memory key. To reuse the memory key, save new information over the option.**

Making calls using memory keys

1. Lift the handset or press the Handsfree key or a line key.
2. Press the memory key for the number that you want to call.

 **If you have selected a prime line (Option 11), you need only press the memory key twice to dial the number or option.**

To activate an option using a memory key

Press the memory key on which the option you want is stored. The option is activated and the memory key light goes on.

Reminder Light-telephone company service



You can program a memory key to remind you when you have a telephone company service activated by turning on the multipurpose light.

 *You must program a separate on and a separate off memory key.*

To save an on and an off reminder light to a memory key

1. Press .
2. Press 1 to turn the light on. The display shows:
Save feature ON to?
OR
press 0 to turn the light off.
The display shows:
Save feature OFF to?
3. Press a memory key.

* You may be required to subscribe or pay a service charge. Contact your local telephone company for codes and charges.

4. Use the dial pad to enter the telephone company service code to turn the feature on or off.*
5. Press .
The display shows:
Press 1st letter to enter a name >.
6. Use the dial pad to enter the feature name (see “Entering numbers, letters and symbols” on page 16).
7. Press . The display shows Saved: Memory key and the name of the feature.
8. Note the name of the option on the memory key paper label for future reference.

Your Venture has a variety of lists. Lists such as Callers and Redial log and track incoming and outgoing calls. Lists such as the Phone list and Directory allow you to add frequently called telephone numbers or customize your Venture. You can use the information stored in these lists to place calls and activate features.

List descriptions

The Phone list...

includes the phone ID and name of each phone in your Venture system. As new Venture phones are added to your system, the ID and name of the phones are automatically added to your Phone list.

The information in the Phone list is stored in your Public Directory. The Phone list can also be accessed by pressing  when the phone is idle.

Numbers in the Phone list can be saved to a memory key.

The Redial list...

stores the last 10 numbers you dialed. It also stores the time each call was made and the duration of the call.

Numbers in the Redial list can be saved to the Directory or to a memory key.

The Callers list...

stores call information for up to 200 incoming calls when you subscribe to Caller ID or Caller ID on Call Waiting.

The Callers list can be set to record information on all calls, unanswered calls or no calls (see “15 Callers log” beginning on page 28). In addition, when Option “16 Repeat caller” on page 28 is set to **Separate calls**, each incoming call, whether from the same number or not, will appear separately in the Callers list. When set to **Combine**, calls from the same telephone number are only logged once. The list will indicate how many times that number tried to call (up to 9x) and the time of the most recent call from that number.

 *If a message is recorded, it will not be combined.*

The Callers list consists of a main list, which includes all call information stored. There are also 15 sublists, one for each telephone line in your system, one for the intercom line, one for the Private Mailbox, one for the Special Mailbox, and one for each of the nine assignable mailboxes. If a line is shared with other phones, the Callers list for that line appears on every phone with that line.

If you do not subscribe to Caller ID or Caller ID on Call Waiting and the Callers list is activated, only internal calls and voice messages are logged.

Numbers in the Callers list can be saved to the Directory or to a memory key.

 *Deleting a Callers list item on one phone, will not remove the item from other Venture sets in your system.*

The Directory...

stores any 200 numbers and names you choose. The Directory includes five sections: a main list, which includes all shared and private directory information for that phone; the Public Directory, which includes all phones in your system and all numbers shared by all telephones in the system; and three Private Directories, which are unique to each phone. You can change the name of each Private Directory. Each Directory indicates how many items it currently contains.

The number of items in a shared Public Directory affects the number of items that can be stored in the three Private Directories of each phone in the system. For example, if the Public Directory has 50 items in it, each user has 150 spaces for use in their Private Directories.

You can save information directly to any of your Directories and view information in either one of your Directories or the main list. Entries saved to each Directory that include only a phone number are listed first in the Directory and are sorted by the first digit. For example, 555-4111 appears before 555-8989. Entries that include a name and a number are listed after the numeric listings and are sorted by name alphabetically.

In addition you can...

- send voice messages from callers listed in your Directory to a specific mailbox
- record personalized greetings for all of the callers listed in your Directory
- record a voice tag that will announce the name of the callers who are listed in your Directory.

Numbers in the Directory can be saved to a memory key.

The Services list...

can store the feature codes and names of up to 20 telephone company services (such as Call Forward or Call Return).

Telephone company services are offered by subscription or on a pay-per-use basis. For more information about features offered in your area, contact your telephone company.

Numbers in the Services list can be saved to the Directory or to a memory key.

The Greetings list...



stores the General greeting and the name, number, type, greeting and voice tag for each of the 14 Venture mailboxes.

You can change the name and type of most of the mailboxes and can record your own greetings and voice tags for any of the mailboxes.

The section titled “Viewing the Greetings list” beginning on page 35 instructs you on using Greetings.

Using the lists



To view a list item

1. Press **Directory**, **Redial**, **Callers**, **Services** or **Greetings** to access the list. If the number is in the Phone list, press  or  to view.

 *If you receive an incoming call while you are in any list, you will be bumped out of the list.*

2. To go to a Directory or Callers sublist, press  to locate the sublist that you want.

 *To locate a name in the Directory quickly, press the key with the first letter of the name until the letter appears on your display.*

3. Press  or  to move through the lists.

To make a call or activate a feature in a list

1. Locate the number in one of Venture's list.
2. Press .

 *If you are in the Callers list and there is a voice message, the voice message will play, otherwise the number on your display will be dialed.*

 *To dial the number when there is a voice message, pick up the handset, press the handsfree key or press a line key.*

3. If you are activating a Services list feature, follow the instructions provided by your telephone company.

To delete an item from any list





1. Locate the item in any list
2. Press **Delete** twice.

Changing list entries

Phone list

You can only change Phone list information on the phone on which information was stored. See options "23 Phone ID" or "24 Phone name" on page 29.

Callers list and Services list

1. Press **Callers** and locate the item you wish to change using  or .
2. Press **Change**.
The display shows:
Use  or dial **Pad**
3. Use  to remove digits and the dial pad to add digits.

 *You cannot change a name.*

Redial list

Once you have located the number you wish to change, simply use the dial pad to enter numbers.

Directory

1. Press **Directory** and locate the item you wish to change using **▲** or **▼**.
2. Press **Change**.
The display shows:
▼=Next *|=Change
3. Press * to make a change to the number and press **Save**.
OR
press **▼** to move to the name and then press *.
4. Press **Save** to confirm your changes.

☞ If Lock lists is turned on, your display will show List is locked No changes made. To turn Lock lists off, see Option “22 Lock lists” beginning on page 29.

☞ You can press **Quit at any time to exit a list without ending a call. Pressing **Goodbye** will exit the list but also end an active call.**

To delete a Phone list entry

You must have more than one Venture in your system.

1. Press **▲** or **▼** to access the phone list.
2. Continue to press **▲** or **▼** until the list item you wish to delete is displayed.
3. Press **Delete** twice to remove the Phone list entry.

☞ Save incoming caller information to your Directory by pressing **Save, **Directory** and **Quit**. Save information to a memory key by pressing **Save** and the memory key when information is displayed.**

Saving to the Services list or Directory

Any information on your display can be saved to the Services list or a Directory. See also “Saving information from another list or a memory key” beginning on page 58.

1. Press **Save**. Display shows:
Save to?

☞ If your display shows List is locked, see option “22 Lock lists” beginning on page 29.

2. Press **Directory** or **Services**.
Your Directory display shows **Enter number**. Once you have entered a number and pressed **Save**, you will then be prompted to enter a name.
Your Services display shows **Enter feature code**.
3. Enter the number (and or name) you want to save using the dial pad.

☞ *To insert a two-second pause in the dialing sequence, press*

Hold.

4. Press **Save**.
The display shows:
Press 1st letter to enter name
5. Press **Save**. If you are saving to the Services list, you are finished.
If you are saving to the Directory, the display shows:
Save to?
Use ► to choose
6. Use ► to select a Directory and press **Save**.
7. Select a mailbox and press **Save**.
8. Record a greeting and press **Save**.
9. Record a voice tag and press **Save**.

Programming Directory information

You can not only store the name and telephone number of a specific person in your Directory, you can also set your Venture to:

- ❶ select a Directory to store the name and telephone number
- ❷ send all messages from that telephone number to the same mailbox
- ❸ record a special greeting that only that telephone number hears
- ❹ record a voice tag to announce the name of that person to you.

Mailboxes and Directory entries

Each Directory entry can be assigned a mailbox. All messages from that Directory entry number are then recorded in that mailbox. If no mailbox is assigned, all messages are recorded in the mailbox for the line on which the incoming call was received.

Example:

Enter the name and telephone number of each member of your baseball team into your Directory. Assign each team member the same mailbox number. All messages left by your team mates (only when calling from the telephone numbers entered in your Directory) are stored in the same mailbox.

To Save to a Directory



1. Press **Save**.
The display shows:
Save to?
2. Press **Directory**.
3. Enter a number and press **Save**.
4. Enter a name and press **Save** (see “Entering numbers, letters and symbols” beginning on page 16).
The display shows: **Save to?**
5. Press ► to locate the Directory to which you want to save information.

6. Press **Save**.
The display shows:
Press number to
Choose mailbox
If you do not want to assign calls from this number to a mailbox, press **Save** again.
7. Using the dial pad, enter one of the following to select a mailbox:
- 1 through 9 for numbered mailboxes
- line keys 1, 2 or 3 for line mailboxes
- 0 for the Private mailbox
- # for the Special mailbox
8. Press **Save**.
The display shows:
Lift Handset to
record greeting
9. If you do not want to record a greeting or one already exists, press **Save** again.
Otherwise, lift the handset and press **Record** to begin.
The display shows:
Recording...
Use SAVE to end

10. Record your greeting and press **Save**. The display shows:
Saved: Greeting
Press RECORD
11. If you do not want to record a voice tag, press **Save** again OR
press **Record**.
The display shows:
Recording...
Use SAVE to end
12. Record your voice tag and press **Save**. The display shows:
Saved: tag
Time left xx:xx
then shows:
Saved and the name of the directory and the name or number saved.

 ***If no mailbox is assigned, all messages received will be recorded in the mailbox for the line on which the incoming call is received.***

To assign a mailbox to an existing Directory entry

1. Press **Directory**.
2. Press ◀ or ▶ until the display shows the sub-directory you want (see “List descriptions” on page 52).
3. Press  until the display shows the name or number you want.
4. Press **Change**.
5. Press  until the display shows:
No mailbox
=Next *=Change
6. Press *. The display shows:
Press number to
Choose mailbox
7. Using the dial pad, press the appropriate key as follows:
- 1 through 9 for numbered mailboxes
- line keys 1, 2 or 3 for line mailboxes
- 0 for the Private mailbox
- # for the Special mailbox
8. Press **Save**.

To name a Private Directory

The default names for Venture's directories are Public, A, B and C. You may change A, B and C as you wish.

1. Press **Directory**.
2. Press **◀** or **▶** to locate the Private Directory (Directory A, B, or C).
3. Press **Change**.
4. Enter the name (see "Entering numbers, letters and symbols" beginning on page 16).

5. Press **Save**.

To Change a Directory

1. Press **Directory**.
2. Press **▲** or **▼** to find the Directory entry.
3. Press **Change**. The display will show:
▼=Next *=Change

4. Press **▼** until the item you wish to change appears on the first line of the display:
telephone number, name, mailbox, greeting and voice tag
5. Press ***** to change the item.
6. Press **Save** to confirm your change.

To delete the entire Directory

1. Press **Options**.
2. Enter 25 using the dial pad. The display shows:
25 Directory
▼=Next *=Erase
3. Press *****. The display shows:
Public Directory
▼=Next *=Erase
4. Use **▼** to find and display the Directory you wish to delete.
5. Press *****. You will then be prompted to press **#** to confirm the deletion of the entire Directory.

Saving information from another list or a memory key

Information can be saved from other lists or the memory keys to the Directory and the Services list.

1. Press the list key or the memory key where the information is stored. If the number is in the Phone list, press **▲** or **▼**.

☞ Information in the Greetings list cannot be saved to another list.

2. If you are in a list with sublists (such as the Callers list), press **◀** or **▶** to locate the sublist you want.
3. Press **▲** or **▼** to find the phone number you want to save.
4. Press **Save**. The display shows **Save to?**

☞ *If your display shows List is locked, see option “22 Lock lists” beginning on page 29.*

5. Press **Services** or **Directory**. If you are saving to the Directory, the display shows **Save to?** Use **▶** to choose.
6. If you are saving to the Services list, you are finished. Otherwise press **▶** to locate the Directory to which you want to save the information.

☞ *If you have saved information to a new location and no longer want it in the original location, you must delete it from the original location.*

To turn a feature on or off in the Services list

Some telephone company services have two codes — one to turn the feature on and one to turn the feature off. You must save each code to a place in the Services list or to two separate memory keys. For more information on saving to a memory key, see “Saving to memory keys” beginning on page 48.





To turn a feature and light on or off

Once programmed, the telephone light on your phone can be set to turn on or off for *one* of the telephone company services (such as Call Forward) that you program to a memory key or to the Services list.

To save each code

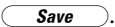
1. Press **Save**.
2. Press **Services**. The display shows **Enter feature code**.
3. Use the dial pad to enter the telephone company service code to turn the feature on or the code to turn the feature off.
4. Press **Save**. The display shows **Press 1st letter to enter name**. If you do not want to enter a name, skip to step 5. Otherwise, use the dial pad to enter the feature code name (see “Entering numbers, letters and symbols” beginning on page 16).
5. Press **Save**. The display shows **Saved: Services** and the name of the feature.

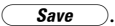
To save a code and a light setting

1. Press .
2. Press 1 to turn the light on. The display shows:
Save feature ON to?
OR
Press 0 to turn the light off. The display shows:
Save feature OFF to?
3. Press .
4. Use the dial pad to enter the telephone company service code to turn the feature on or the code to turn the feature off.
5. Press . The display shows Press 1st letter to enter name.
6. Use the dial pad to enter the feature name (see “Entering numbers, letters and symbols” beginning on page 16).
7. Press . The display shows Saved: Services and the name of the feature.

To set up the Callers list

To customize the type of call information you want to store and the way it appears in your Callers list, set Option “15 Callers log” on page 28 and Option “16 Repeat caller” on page 28.

Callers list display information

If your caller leaves a voice message, your display shows:

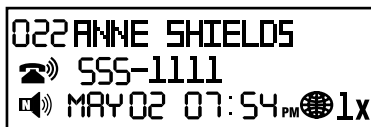

The *first line* shows the list number (001 to 200) and the name of the caller.

 *If the phone number of a call received matches one that you have programmed on a memory key or in the Directory, the display shows the name as you entered it in the Directory or memory key.*

The *second line* shows the type of call and the phone number of the caller. If you have returned the call, the  icon will also be displayed.

Callers list icons

Icons on the second line



Answered call







Unanswered call



Call Waiting call (answered or unanswered)





Icons on the third line

The *third line* indicates if the call displayed is new, the date and time of the most recent call, whether there is a voice message, whether the call was long distance, and how many times the caller called (only when no message is left).

- N** The call is new
-  A new voice message
-  A new message—viewed but not played
-  A previously viewed and played message
-  The call is long-distance*
- 4X** The caller called four times
-  An area code (such as 605) has been stripped

*Icon may not be available from your local telephone company.

To delete a single Callers list entry

1. Press .
2. Press  or  to move to the Callers list entry you wish to delete.
3. Press  twice.





To delete entire Callers list

All voice messages stored in the Callers list are deleted.

1. Press .
2. Press  twice.

To delete an entire Callers list sublist

All voice messages stored in the Callers sublist are deleted.

1. Press .
2. Press  or  until the name of the sublist you want is on your display.
3. Press  twice.

The following status messages may be displayed when your Venture set is idle.

If you have more than one status message, you can view additional messages using ►. When you clear one status message from the display, the next one appears.

Status messages

Check line cord

A line cord may be damaged, not plugged in, or otherwise disabled.

Copying...

Directory

The Public Directory in one Venture system is being copied to another Venture phone.

Don't disturb ON

The Don't disturb option is on and your phone will not ring aloud for incoming calls.

Feature ON

When you program Feature On to your Services list or to a memory key, this message reminds you that a telephone company services (such as Call Forward) has been activated.

Line x Reserved

This message means that you have reserved line 1, 2 or 3.

Message Waiting on line X

If you subscribe to voice message services from your telephone company, your phone display indicates when you have a message waiting, and on which line the message is stored.

Ringer is OFF

The ringer for a line or intercom is turned off on your phone.

xxx New caller(s)

Indicates the number of new callers that have been added to your Callers list since you last reviewed the list.

xxx Calls bumped

Indicates the number of calls that have been dropped from your Callers list.

xxx New message(s)

Indicates the number of new voice messages that have been added to your Callers list since you last reviewed it.

xx New Phone(s)

Indicates the number of new phones that have been added to your Venture system.

xx New Service(s)

Indicates the number of new services that have been added to your Services list.



Troubleshooting is designed to help you overcome difficulties that may occur when installing and using a new Venture with TAD.

Blank display

Your display is blank and the lights on your phone are not working.

1. Check that the power adapter is plugged into a working power outlet and that proper connections have been made to the CAM.
2. Be certain that you have an 8-wire cord connected from the CAM to your Venture phone.

Display language error

1. Press .
2. Press 28.
3. Press *.
4. Press  repeatedly until your display shows the language you want.
5. Press *.

The message “Check line cord” appears on the display

Check for dial tone on line 1. If you have dial tone but your display still shows “Check line cord”, unplug the power cord for a few seconds and then reconnect. The display should now be clear. If you do not hear a dial tone, see the following section “No dial tone” for further instructions.

No dial tone

1. Check the connections of line cords from the phone jack to the CAM and from the CAM to your Venture phone.
2. Ensure that working telephone lines are connected to the wall jack(s).
3. If you have a dial tone on the handset but not when you are using the Handsfree speaker, turn off the headset using option 05. If **Headset** is on, the Handsfree speaker is disabled.

4. If you have dial tone on the Handsfree speaker but not when you are using the handset, ensure that the handset cord is firmly plugged into the handset and the handset jack on the back of your phone.

Communication problems

You have more than one Venture phone linked together, and you experience any of the following:

- Other Venture phones do not appear in your phone list.
- Public directory information is not shared.
- You experience difficulty calling other Venture phones.
- Your display shows **Phone not responding** or **System busy** when you try to place an intercom call or page other phones.
- The status of other Venture phones in your system is not shown — instead you see three dots (...).

In order to communicate, all Venture phones must share line 1.

1. To ensure that the same telephone line is connected to line 1 on all Venture phones you can:
 - Press **Line 1**.
 - If you do not hear dial tone, see “No dial tone” on page 63.
 - If you hear dial tone, leave the handset off hook and check every Venture phone. The **Line 1** indicator light should be lit.
 - If the **Line 1** indicator light is not turned on, verify that the jacks are wired correctly and the line cords are connected correctly.
2. Press **Goodbye** or hang up the handset.
3. Press **▼**. For every Venture phone in your system, the display should show the **Name** assigned to the phone, **Phone xx** and one of four possible status messages:

- **idle** — the phone is not in use
 - **busy** — the phone is in use
 - **owner** — this is the phone you are using
 - **...** — the phones aren't communicating or the phone has been removed from the system.
4. Call your phone from any Venture phone that does not appear in the Phone list.
 5. If the call was placed successfully, the phone will now appear in the Phone list. Repeat step 3 to verify.
 6. If all the phones appear in the Phone list, call each phone. If you don't encounter problems, you are finished. If your display shows, **Phone not responding** or you continue to have problems seeing other Venture phones in the list, disconnect all non-Venture telephones from line 1 and begin installation again (see “Installing the phone” on page 8). Remember to install and test one Venture phone at a time.

- If you have disconnected and then reconnected all Venture phones and still have problems, call 1-800-574-1611 for assistance.

Interference caused by non-Venture phones or unused telephone jacks

Some non-Venture equipment connected to the telephone line that is used as line 1 on your Venture system can cause interference. Call 1-800-574-1611 for detailed instructions on correcting this problem.

Duplicate ID is displayed for unexplained reason

1. Press **Options**.
2. Enter 23. The display shows,
Phone ID
☐ = Next * = Change
3. Press *.
4. Enter your two-digit ID.
5. Press *.
6. If the display shows:
Invalid Phone ID
Please try again
Repeat steps 1 to 5 using a different number.

You can't hear

Use **☐** to adjust the volume of the handset, the Handsfree speaker or both.

You forgot your password

You can't enter the Options list because you have forgotten the password.

1. Press **Options**. The display reads:
Please enter Password ▶.
2. Enter the month, date and hour (in 24 hour format) displayed on the phone (6 digits).
For example, if your phone is displaying
FEB 21 3:45PM, the password would be 022115.
3. Press **☐** repeatedly until your display shows 21 Password.
4. Press *. The display shows Password > and the number.

Your caller can't hear you

1. If you are using the handset, check the handset cord connections.
2. If you are using the Handsfree speaker, make sure that you have not activated mute. The light beside the Handsfree/Mute key flashes when mute is turned on.

You can't dial from the Callers list

You can dial a number in the Callers list, but the call does not connect or you get a recorded announcement.

- You may need to add or delete an area code. See "17 Area codes" on page 28.

You can't turn off the message waiting light

Your message waiting light cannot be turned off using Option, "10 Clear Msg. Wtg." on page 27.

The problem is related to the type of message waiting signalling provided by your telephone company, and not with your Venture phone.

- Report the problem to your telephone company.

A caller hears, "We are unable to take your call. Please call back later."

Your Venture set's memory is full. You must delete old messages or greetings.

Venture set appears to "freeze" for a moment after recording or deleting an item

The Venture TAD is compressing its memory and updating the available recording time.

After entering your Remote access password you hear nothing

Enter the last digit of your password again. If you still hear nothing, hang up and dial Remote access again, this time entering your password slowly.

The display information is garbled

Pick up the handset. The display should clear. If a list item is corrupted, you must delete it and enter it again.

Calls are not being answered by the TAD

Ensure that Option 31 is ON.

Your Greeting plays twice

Ensure that Option 32 is OFF.

he Venture phone is fully supported by Aastra.

Warranty and repairs

If you have a problem with your phone, return it to where it was purchased.

Cleaning the display

Use only a soft cloth soaked in isopropyl alcohol to clean the display.

Warning: Do *not* use a dry cloth— it might scratch the surface. Do *not* use ketone, acetone, toluene or xylene. They may damage the coating.

General inquiries

If you have read this guide and consulted the Troubleshooting section and still have questions, visit our web site <http://www.aastra.com> or call 1-800-574-1611.

Play/Action key This key (●) is located in the center of the arrow keys on the right side of your Venture phone. It is used to dial anything on your display, play messages or to change options.

Call log This is another name for the Callers list.

Call Waiting This is a telephone company service to which you can subscribe. The phone beeps, letting you know that a call is waiting. If you also have Caller ID on Call Waiting, the display shows who is calling. You can choose to take the second call or to continue with the first call.

Caller ID This is a telephone company service to which you can subscribe. It provides information (usually the name and phone number of the caller) on incoming calls. This information is shown on your Venture phone display and stored in your Callers list.

Conference calling A three-way call between you and callers on two other lines. On your Venture phone you can conference two separate phone lines or one phone line and an intercom line.

Connecting block A plastic block containing metal wiring terminals that connect one group of wires to another. Each wire is usually connected to several other wires in a bus (an electrical connection that allows two or more wires or lines to be connected together) or in a common arrangement.

Daisychain A method of connecting devices in a series. The phone signal is passed through the chain from one device to the next.

Differentiated ring This is a telephone company service to which you can subscribe. It enables you to have a second phone number with a unique ring on a single phone line.

Display prompts Instructions shown on your display.

Flash This Venture feature works like a break in the phone line connection. For example, if you subscribe to Call Waiting or Caller ID on Call Waiting from your telephone company, when you are on a call and second call comes in on the same line, you can press  to answer the other call.

Home run (Star) Phone system wiring in which the individual cables run from each phone to a connecting block where your phone lines are brought into your building.

KSU-less systems Systems, like Venture, that include only phones directly linked to each other so that they can call each other and share information and lines.

Lists Information storage areas from which information can be used to place calls and activate features.

Lock lists A security feature that prevents unauthorized users from deleting or changing items in lists, such as your Directory or Callers list.

Memory key Eight memory keys are located on the lower right side of your Venture phone. When programmed with a number, a memory key enables you to dial frequently called numbers by pressing the memory key twice. Memory keys can also be used to activate telephone company services and Venture features.

Message Waiting If you subscribe to a call messaging service from your telephone company, you will see this prompt on your display when a message has been left for you.

Navigational keys The four arrow keys that surround the action key (●): ▲, ▼, ► and ◀. With these keys you can move up, down, and sideways through the Callers list, Directory, Phone list, Redial list and Services list.

Non-square In the Venture system, a system configuration in which the first line must be the same on all the phones, but the other lines can be arranged in any order.

Phone list The name and identification number of all phones in a Venture system are automatically stored in this list. You can view Phone list information by pressing  when your phone isn't busy, or by accessing your Public Directory.

POTS Plain Old Telephone Service is what you receive during a power failure. You can receive and make calls on line 1, but you cannot use any other lines or features. The display on your phone is blank when your phone is operating in POTS mode.

Square system A system configuration in which the same lines in the same order appear on each phone.

Star See Home run.

Teladapt jack A wall jack that is the termination point for the telephone lines being connected to phones or other communications equipment in a building.

Termination module An Aastra solution to problems that sometimes occur when analog phones share lines with phones in any KSU-less system.

Tip and ring The pair of wires provided for each telephone line from the telephone company's central office.

Twisted pair Two insulated copper wires twisted around each other to reduce interference.

This appendix is intended for use by installers or individuals with system wiring experience. It provides in-depth information required to complete the wiring of a Venture system, from the connecting blocks through the jacks and the Venture cord adapter module (CAM) to a Venture phone. It also provides information relevant to new installations and previously wired facilities.

Running cable to phone jacks

The following factors should be considered when new wiring is required for new installations or to provide additional phone lines.

- The same telephone service provider line must appear as line 1 on each phone so that the phones in the system can communicate.
- Three (or more) twisted-pair cable is recommended.

- Running cable from the connecting blocks to each telephone (a home run configuration) is recommended.
- Running a cable from one phone to the next (a daisychain configuration) is also supported, although it may cause more work if the system is modified later.
- Individual cables for each phone line can also be run; however, there is no advantage in incurring the additional expense.

Wiring the jacks

- One jack for each telephone is recommended.
- On a standard 6-pin teledapt jack, the lines terminate on the tip and ring pins as follows:
 - line 1—green and red pins,
 - line 2—black and yellow pins,
 - line 3—white and blue pins.

 **Wire color may vary from region to region.**

Two jack examples

The following two examples explain how to connect three telephone service provider lines terminated on two jacks to a CAM. Other more simple configurations, shown only from the jack to the phone, are explained in the section titled “Installing the phone” on page 8.

 ***Applying the instructions presented in these two examples should enable you to connect telephone service provider lines from the connecting blocks in a building to the CAM for any configuration. If you require more information, call 1-800-574-1611.***

Line 1 on a separate jack and lines 2 and 3 on one jack

1. Connect line 1 to the red and green pins of the first teledapt jack.
2. Connect one end of a 6-wire cord to the first teledapt jack and the other end to port 1 on the CAM.
3. Connect line 2 to the red and green pins of the second teledapt jack.
4. Connect line 3 to the black and yellow pins of the second teledapt jack.
5. Connect one end of the 6-wire cord to the second teledapt jack and the other end to port 2 on the CAM.

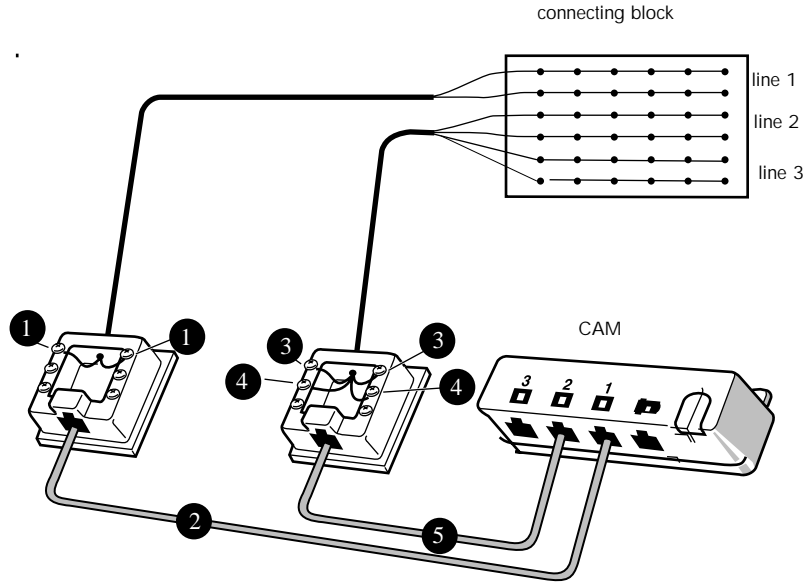

Lines 1 and 2 on one jack and line 3 on a separate jack

1. Connect phone line 1 to the red and green pins of the first teledapt jack
2. Connect phone line 2 to the black and yellow pins of the first teledapt jack.
3. Connect one end of the 6-wire cord to the first teledapt jack and the other end to port 1 on the CAM.
4. Connect line 3 to the red and green pins of the second teledapt jack.
5. Connect one end of the 6-wire cord to the second teledapt jack and the other end of the line cord to port 3 on the CAM.

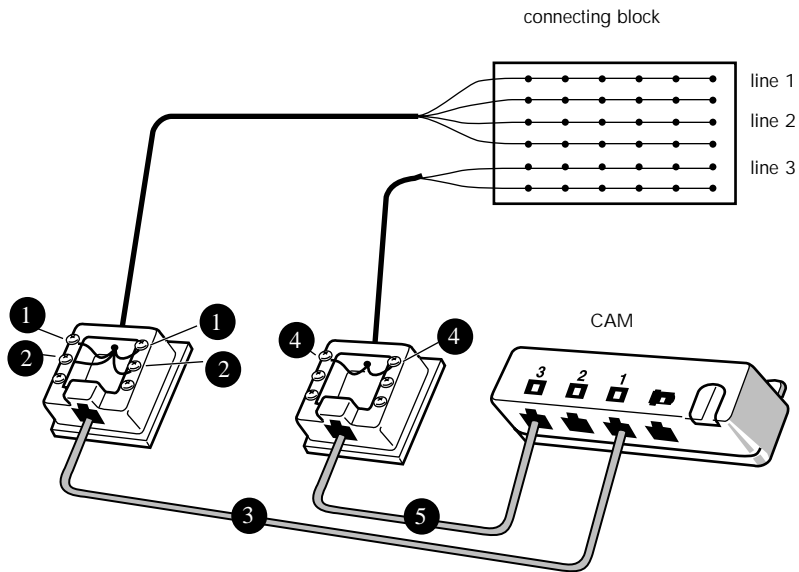

Connecting an ISDN line to a single Venture set

1. Connect your line to your phone box.
2. From the phone box, connect your lines to the ISDN Adapter.
3. Run a line jack to either Port 2 or Port 3 on the CAM.
4. Connect the ISDN Adapter to your computer.

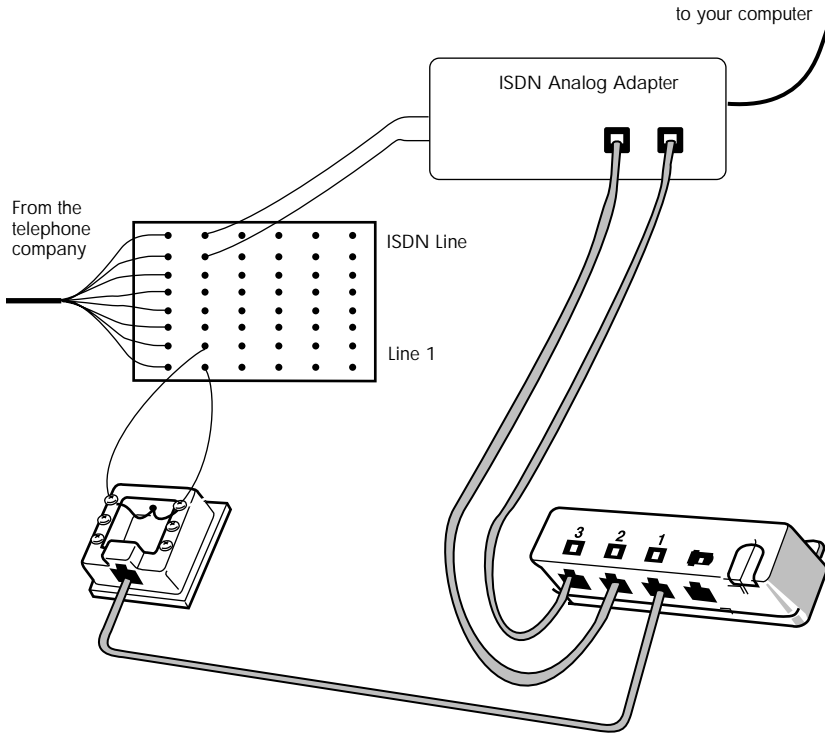

Canadian regulatory information

Industry Canada Notice

The Industry Canada label identifies certified equipment. This certification means that the equipment meets certain telecommunications network protective, operational and safety requirements. The Department does not guarantee the equipment will operate to the user's satisfaction.

Before installing this equipment, users should ensure that it is permissible to be connected to the facilities of the local telecommunications company. The equipment must also be installed using an acceptable method of connection. The method of connection approved for this equipment as designated by D.O.C. Standard CS-03 is a CA11A/CA14A or CA11W/CA14W connection arrangement. The A or W suffix

indicates that either desk or wall mounting is approved. In some cases, the company's inside wiring associated with a single line individual service may be extended by means of a certified jack-plug-cord ensemble (telephone extension cord). The customer should be aware that compliance with the above conditions may not prevent degradation of service in some situations.

Existing telecommunications company requirements do not permit their equipment to be connected to customer provided jacks except where specified by individual telecommunications company tariffs.

Repairs to certified equipment should be made by an authorized Canadian maintenance facility designated by the supplier. Any repairs or alterations made by the user to this equipment, or equipment malfunctions, may give the telecommunications company cause

to request the user to disconnect the equipment.

Users should ensure for their own protection that the electrical ground connections of the power utility, telephone lines and internal metallic water pipe system, if present, are connected together.

This precaution may be particularly important in rural areas.

CAUTION: Users should not attempt to make electrical ground connections themselves, but should contact the appropriate electric inspection authority, or electrician, as appropriate.

NOTICE : The Ringer Equivalence Number (REN) assigned to each terminal device denotes the percentage of the total load to be connected to a telephone loop which is used by the device, to prevent overloading. The termination of a loop may consist of any combination of devices subject only to the requirement that the sum of the REN of all the devices does not exceed 100.

This telephone has been tested and found to comply with the limits for a Class B digital device in accordance with the Canadian EMI requirement ICES-003.

CAUTION : To eliminate the possibility of accidental damage to cords, plugs, jacks and the telephone, do not use sharp instruments during the assembly procedures.

WARNING : Do not insert the plug at the free end of the receiver cord directly into a wall or baseboard jack.

Such misuse can result in unsafe sound levels



The exclamation point within an equilateral triangle is intended to alert the user to the presence of important operating and maintenance (serving) instruction in the literature accompanying the product.

This symbol on the product is also used to identify the following important information:

Shock Hazard Warning:

To avoid potential electrical shock hazard to personnel or damage to the telephone, use only the manufacturer supplied equipment and installation procedures. Specifically, use only 6 conductor modular Teladapt plug/ cords with this product, and the AC transformer must be CSA/UL or CSA-NRTL/C approved Class 2, level C, rated as follows:

For North American Markets mains nominal AC voltage 110-117V:

For Venture- Input: 117/120VAC, 50/60Hz, 12W and Output: 16VAC 500 mA.

For International Markets mains nominal AC voltage 220-240V:

For Venture- Input: 220/240VAC, 50/60Hz, 12W and Output: 16VAC 500 mA.

Substitution of non approved equipment will void the Aastra warranty.

For warranty and repairs in Canada call: 1-800-574-1611.

U.S. regulatory information

Radio/TV interference

Terminals equipped with electronic push-key dials generate and use radio frequency energy, and if not installed and used properly and in strict accordance with the manufacturer's instructions, may cause interference to radio and television reception.

These terminals have been tested and found to comply with the limits for a Class B digital device in accordance with the specifications in Part 15 of the FCC rules. While these rules are designed to provide reasonable protection, there is no guarantee that interference will not occur in a particular installation. You can determine whether interference occurs by monitoring your radio or television reception while placing a call.

If your terminal causes interference, one of the following measures may correct the problem:

Reorient or relocate the receiving TV or radio antenna, where this may be done safely.

To the extent possible, move the telephone and the radio or television farther away from each other, or connect the telephone and the radio or television to outlets on separate circuits.

Consult the dealer or an experienced radio/television technician for additional suggestions.

Federal Communications Commission (FCC) notice

FCC registration number: This telephone equipment complies with Part 68, Rules and Regulations, of the FCC for direct connection to the Public Switched Telephone Network. (The FCC registration number appears on a sticker affixed to the bottom of the telephone.)

Note: FCC registration does not constitute an expressed or implied guarantee of performance.

Your connection to the telephone line must comply with these FCC rules:

Use only an FCC standard RJ11W/RJ14W or RJ11C/RJ14C network interface jack and FCC compliant line cord and plug to connect this telephone to the telephone line. (To connect the telephone, press the small plastic tab on the plug at the end of the telephone's line cord. Insert into a wall or baseboard jack until it clicks. To disconnect, press the tab and pull out.)

If a network interface jack is not already installed in your location, you can order one from your telephone company. Order RJ11W/RJ14W for wall-mounted telephones or RJ11C/RJ14C for desk/table use. In some states, customers are permitted to install their own jacks.

Your telephone may not be connected to a party line or coin telephone line. Connection to Party Line Service is subject to state tariffs. (Contact the state public utility commission, public service commission or corporation commission for information.)

It is no longer necessary to notify the Telephone Company of your phone's Registration and REN numbers. However, you must provide this information to the telephone company if they request it.

If this terminal equipment causes harm to the telephone network, the telephone company will notify you in advance that temporary discontinuance of service may be required. If advance notice isn't practical, the telephone company will notify the customer as soon as possible. Also, you will be advised of your right to file a complaint with the FCC if you believe it necessary.

The telephone company may make changes in its facilities, equipment, operations or procedures that could affect the operation of the equipment. If this happens the telephone company will provide advance notice in order for you to make necessary modification to maintain uninterrupted service.

Do not attempt to repair this equipment yourself. If trouble is experienced with this equipment, for repair or warranty information please contact 1-800-574-1611.

If the equipment is causing harm to the telephone network, the telephone company may request that you disconnect the equipment until the problem is resolved.

Signaling method: The unit's push-key dial allows it to signal in tones (DTMF). It can complete calls to local and long distance lines and can also complete long distance calls via computer-phone systems such as MCI or SPRINT.

Ringer Equivalence Number:

The FCC Registration label (on bottom of phone), includes a Ringer Equivalence Number (REN), which is used to determine the number of devices you may connect to your phone line. A high total REN may prevent phones from ringing in response to an incoming call and may make placing calls difficult. In most areas, a total REN of 5 should permit normal phone operation. To determine the total REN allowed on your telephone line, consult your local telephone company.

Hearing aids: The telephone is compatible with hearing aids equipped with an appropriate telecoil option and is compliant with the requirements for hearing aid compatibility of the Americans with Disabilities Act (ADA).

Programming emergency numbers: When programming emergency numbers and/or making test calls to emergency numbers:

1. Check with local authorities before making any test calls to emergency numbers.
2. Remain on the line and briefly explain to the dispatcher the reason for calling before hanging up.
3. Perform such activities in the off-peak hours, such as early mornings or late evenings.

CSA-NRTL/C installation instructions

Warning: Avoid electrical shock hazard to personnel or equipment damage observe the following precautions when installing telephone equipment:

1. Never install telephone wiring during a lightning storm.
2. Never install telephone jacks in wet locations unless the jack is specifically designed for wet locations.
3. Never touch uninsulated telephone wires or terminals unless the telephone line has

been disconnected at the network interface.

4. Use caution when installing or modifying telephone lines.

Important safety instructions

When using your telephone equipment, basic safety precautions should always be followed to reduce risk of fire, electric shock and injury to persons, including the following:

1. Read and understand all instructions.
2. Follow the warnings and instructions marked on the product.
3. Unplug this product from the wall outlet before cleaning. Do not use liquid cleaners or aerosol cleaners. Use a damp cloth for cleaning.

4. Do not use this product near water, for example, near a bath tub, wash bowl, kitchen sink, or laundry tub, in a wet basement, or near a swimming pool.
5. Do not place this product on an unstable cart, stand or table. The product may fall, causing serious damage to the product.
6. This product should never be placed near or over a radiator or heat register. This product should not be placed in a built-in installation unless proper ventilation is provided.
7. Do not allow anything to rest on the power cord. Do not locate this product where the cord will be abused by persons walking on it.
8. Do not overload wall outlets and extension cords as this can result in the risk of fire or electric shock.

9. Never spill liquid of any kind on the product.
10. To reduce the risk of electric shock do not disassemble this product, but have it sent to a qualified service person when some service or repair work is required.
11. Unplug this product from the wall outlet and refer servicing to qualified service personnel under the following conditions:
 - (A) When the power supply cord or plug is damaged or frayed.
 - (B) If the product has been exposed to rain, water or liquid has been spilled on the product, disconnect and allow the product to dry out to see if it still operates; but do not open up the product.
 - (C) If the product housing has been damaged.
 - (D) If the product exhibits a distinct change in performance.
12. Avoid using a telephone during an electrical storm. There may be a remote risk of electric shock from lightning.
13. Do not use the telephone to report a gas leak in the vicinity of the leak.
14. **CAUTION:** To eliminate the possibility of accidental damage to cords, plugs, jacks, and the telephone, do not use sharp instruments during the assembly procedures.
15. **WARNING:** Do not insert the plug at the free end of the handset cord directly into a wall or baseboard jack. Such misuse can result in unsafe sound levels or possible damage to the handset.
16. Save these instructions.



The exclamation point within an equilateral triangle is intended to alert the user to the presence of important operating and maintenance (servicing) instruction in the literature accompanying the product.

This symbol on the product is used to identify the following important information:

Shock Hazard Warning:

To avoid potential electrical shock hazard to personnel or damage to the telephone, use only the manufacturer supplied equipment and installation procedures. Specifically, use only 6-conductor modular Teladapt plug/cords with this product, and the AC transformer must be CSA/UL or CSA-NRTL/C approved Class 2, level C, rated as follows:

For North American Markets mains nominal AC voltage 110-117V:

For Venture- Input: 117/120VAC, 50/60Hz, 12W and Output: 16VAC 500 mA.

For International Markets mains nominal AC voltage 220-240V:

For Venture- Input: 220/240VAC, 50/60Hz, 12W and Output: 16VAC 500 mA.

Substitution of non approved equipment will void the Aastra warranty.

Warranty and repair

If you have several telephones and you are having problems with all of them, or if your telephone works in some outlets and not in others, your problem may originate with the local telephone lines or with central office equipment. Contact your telephone company repair service listed in the front of your phone book.

Should the terminal fail during the twelve month warranty period,

please return it for repair to the manufacturer, or to the authorized agent as specified in the product literature. You will be responsible for shipping charges, if any, and for presenting proof of your telephone's date of purchase.

If the terminal is covered by a Telephone Company Maintenance Agreement, follow the procedure set forth in the Maintenance Agreement for obtaining repair or replacement of the terminal.

If the terminal is no longer covered by the manufacturer or its authorized agents' Warranty, and is not covered by a Telephone Company Maintenance Agreement, you may return the terminal to the manufacturer or its authorized agents for repair or refurbishment. You will be billed for any repairs.

Repair to this equipment can only be made by Aastra Telecom Inc. and its authorized agents, and by others who may be authorized by the FCC.

Questions about the warranty or requests for the manufacturer's policy and procedure on repair and refurbishment should be directed to the manufacturer or authorized agent as specified in the product literature.

Manufacturer's limited twelve month warranty Coverage

The manufacturer warrants this terminal against defects and malfunctions for a period of twelve months from the date of original purchase. If there is a defect or malfunction, Aastra Telecom Inc. or its authorized agents will, at its option, and as the exclusive remedy, either repair or replace the terminal at no charge if returned within the warranty period.

If replacement parts are used during repair, these parts may be refurbished or may contain refurbished materials. If it is necessary to replace the terminal, it may be replaced with a refurbished terminal of the same design and color. If it should become

necessary to repair or replace a defective or malfunctioning terminal set under this warranty, the provisions of this warranty shall apply to the repaired or replaced terminal until the expiration of ninety (90) days from the date of pick-up, or the date of shipment to you of the repaired or replacement set or until the end of the original twelve month warranty period whichever is later.

Exclusions: Northern Telecom Inc. does not warranty this terminal to be compatible with the equipment of any particular telephone company. This warranty does not extend to damage to product resulting from improper installation or operation, alteration, neglect, abuse, misuse, fire or natural causes such as storms or floods after the terminal is in your possession.

Northern Telecom shall not be liable for any incidental or consequential damages, including but not limited to loss, damage, or expense directly or

indirectly arising from the customer's use or inability to use this product, either separately or in combination with other equipment. This paragraph, however, shall not apply to consequential damages for injury to the person in the case of telephones used or bought for use primarily for personal, family, or household purposes.

The warranty sets forth the entire liability and obligations of Northern Telecom Inc. and its authorized agents with respect to breach of warranty, and the warranties set forth or limited herein are the sole warranties and are in lieu of all other warranties, expressed or implied, including warranties or fitness for particular purpose and merchantability.

State law provisions: This warranty gives you specific legal rights and you may have other rights which vary from state to state. Some states do not allow the exclusion of incidental or consequential damages or allow limitation on implied warranties or their duration, so that above exclusions or limitations may not apply.