

Thank you for using our products.

**INSTALLATION INSTRUCTIONS  
 SERIES AH-WP INDOOR/OUTDOOR AUDIBLE HORN APPLIANCES**

Use this product according to this instruction manual. Please keep this instruction manual for future reference.

**GENERAL:**

Cooper Wheelock's AH-WP Audible Horn Appliances are designed to provide a selectable continuous horn or code 3 tone when connected directly to the Fire Alarm Control Panel (FACP), or provide a synchronized code 3 horn when used in conjunction with a Sync Module (SM), Dual Sync Module (DSM) or Wheelock's Power Supplies. The AH-WP Appliances are UL Listed under UL Standard 464 for Audible Signal Appliances. The AH-24WP is ULC Listed under Standard CAN/ULC-S525-99 for Audible Signaling Appliances. They are listed for indoor and outdoor use and can be mounted to a 4" backbox (See Mounting Options).

AH-WP Appliances can be field set to provide either High (HI) dBA, Medium (MED) dBA or Low (LO) dBA sound output.

All AH-WP models are designed for use with either filtered DC (VDC) or unfiltered Full-Wave-Rectified (FWR) input voltage. All inputs are polarized for compatibility with standard reverse polarity supervision of circuit wiring by a FACP.

**NOTE:** The code 3 horn incorporates the temporal pattern (1/2 second on, 1/2 second off, 1/2 second on, 1/2 second off, 1/2 second on, 1-1/2 off and repeat) specified by ANSI/NFPA for standard emergency evacuation signaling. The code 3 horn shall be used only for fire evacuation signaling and not for any other purpose.

**NOTE:** All CAUTIONS and WARNINGS are identified by the symbol . All warnings are printed in bold capital letters.

 **WARNING: THE AH-WP APPLIANCE IS A "FIRE ALARM DEVICE - DO NOT PAINT."**

 **WARNING: PLEASE READ THESE INSTRUCTIONS CAREFULLY BEFORE USING THIS PRODUCT. FAILURE TO COMPLY WITH ANY OF THE FOLLOWING INSTRUCTIONS, CAUTIONS AND WARNINGS COULD RESULT IN IMPROPER APPLICATION, INSTALLATION AND/OR OPERATION OF THESE PRODUCTS IN AN EMERGENCY SITUATION, WHICH COULD RESULT IN PROPERTY DAMAGE AND SERIOUS INJURY OR DEATH TO YOU AND/OR OTHERS.**

**SPECIFICATIONS:**

Model	Regulated Voltage (VDC/VRMS)	UL Voltage Range (VDC/VRMS)	ULC Voltage Range (VDC/VRMS)	Maximum RMS Current (AMPS)					
				DC			FWR		
				Lo	Med	Hi	Lo	Med	Hi
AH-24WP	24	16-33	20-31	0.021	0.043	0.080	0.041	0.051	0.090
AH-12WP	12	8-17.5	----	0.058	0.108	0.192	0.059	0.109	0.209

Model AH-12WP is not ULC listed.

Model	ULC Voltage (VDC/VRMS)	Average Current (AMPS)		
		Lo	Med	Hi
AH-24	20.0	.014	.020	.035
	24.0	.017	.025	.050
	31.0	.021	.030	.065

Description	Volume	Reverberant dBA Per UL 464			Anechoic Per CAN/ULC-S525-99		
		16.0VDC	24VDC	33.0VDC	16.0VDC	24VDC	33.0VDC
Continuous Horn	Low	80	83	86	88	90	92
	Medium	85	88	91	90	95	97
	High	88	91	93	92	97	99
Code 3 Horn	Low	75	79	82	88	90	92
	Medium	80	84	86	90	95	97
	High	84	87	90	92	97	99

Description	Volume	Reverberant Per UL 464		
		8.0VDC	12VDC	17.5VDC
Continuous Horn	Low	80	83	86
	Medium	85	88	91
	High	88	91	93
Code 3 Horn	Low	75	79	82
	Medium	80	84	86
	High	84	87	89

**NOTES:**

- All models are UL/ULC Listed for indoor and outdoor use with a temperature range of -31°F to +151°F (-35°C to 66°C) and maximum humidity of 98% RH.

-3 dBA: 48 degrees left, 41 degrees right
-6 dBA: 50 degrees left, 58 degrees right

**⚠ WARNING: CHECK THE MINIMUM AND MAXIMUM OUTPUT OF THE POWER SUPPLY AND STANDBY BATTERY AND SUBTRACT THE VOLTAGE DROP FROM THE CIRCUIT WIRING RESISTANCE TO DETERMINE THE APPLIED VOLTAGE TO THE SIGNALING APPLIANCE.**

**⚠ WARNING: FOR UL APPLICATIONS THESE APPLIANCES WERE TESTED TO THE OPERATING VOLTAGE LIMITS OF 16-33 VOLTS FOR 24V MODELS AND 8-17.5 VOLTS FOR 12V MODELS USING FILTERED (DC) OR UNFILTERED FULL-WAVE-RECTIFIED (FWR). DO NOT APPLY 80% AND 110% OF THESE VOLTAGE VALUES FOR SYSTEM OPERATION.**

**⚠ WARNING: FOR ULC APPLICATIONS THESE APPLIANCES WERE TESTED TO THE OPERATING VOLTAGE LIMITS OF 20-31 VOLTS FOR 24V MODELS AND 10.5-15.6 VOLTS FOR 12V MODELS USING FILTERED (DC) OR UNFILTERED FULL-WAVE-RECTIFIED (FWR). APPLY 80% AND 110% OF THESE VOLTAGE VALUES FOR SYSTEM OPERATION.**

**⚠ WARNING: MAKE SURE THAT THE TOTAL RMS CURRENT, TOTAL AVERAGE CURRENT AND TOTAL PEAK CURRENT REQUIRED BY ALL APPLIANCES THAT ARE CONNECTED TO THE SYSTEM'S PRIMARY AND SECONDARY POWER SOURCES, NAC CIRCUITS, SM, DSM SYNC MODULES OR WHELOCK'S POWER SUPPLIES DO NOT EXCEED THE POWER SOURCES' RATED CAPACITY OR THE CURRENT RATINGS OF ANY FUSES ON THE CIRCUITS TO WHICH THESE APPLIANCES ARE WIRED. OVERLOADING POWER SOURCES OR EXCEEDING FUSE RATINGS COULD RESULT IN LOSS OF POWER AND FAILURE TO ALERT OCCUPANTS DURING AN EMERGENCY, WHICH COULD RESULT IN PROPERTY DAMAGE AND SERIOUS INJURY OR DEATH TO YOU AND/OR OTHERS.**

When calculating the total currents: Use Table 1 to determine the highest value of "RMS Current" for an individual AH Appliance (across the expected operating voltage range of the AH Appliance) or use Table 1A to determine the highest value of "Rated Average Current" of an individual AH Appliance (across the expected voltage range of the AH Appliance), then multiply these values by the total number of AH Appliances; be sure to add the currents for any other appliances, powered by the same source and include any required safety factors.

If the peak current exceeds the power supplies' peak capacity, the output voltage provided by the power supplies may drop below the listed voltage range of the appliances connected to the supply and the voltage may not recover in some types of power supplies. For example, an auxiliary power supply that lacks filtering at its output stage (either via lack of capacitance and/or lack of battery backup across the output) may exhibit this characteristic.

**⚠ CAUTION: Audible Horn appliances are not designed to be used on coded systems in which the applied voltage is cycled on and off.**

**⚠ WARNING: THE AUDIBLE HORN APPLIANCES MUST BE FIELD SET TO THE DESIRED TONE AND dBA SOUND OUTPUT LEVEL BEFORE THEY ARE INSTALLED. THIS IS DONE BY PROPERLY INSERTING A JUMPER PLUG IN ACCORDANCE WITH THESE INSTRUCTIONS. INCORRECT SETTINGS WILL RESULT IN IMPROPER PERFORMANCE, WHICH COULD RESULT IN PROPERTY DAMAGE AND SERIOUS INJURY OR DEATH TO YOU AND/OR OTHERS.**

**SOUND OUTPUT (SPL) SETTINGS:**

Figure 1: Showing Location of Jumper Plug J1 and J1.

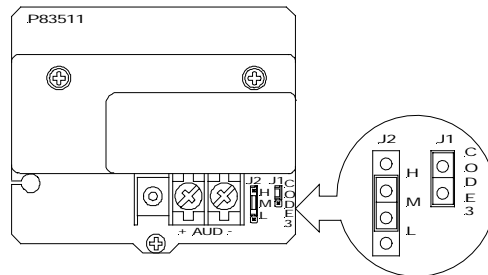

Factory setting is on Medium dB and Code 3.

Figure 2: Jumper Plug Settings for High, Medium, Low dB, Code 3 Horn and Continuous Horn Setting

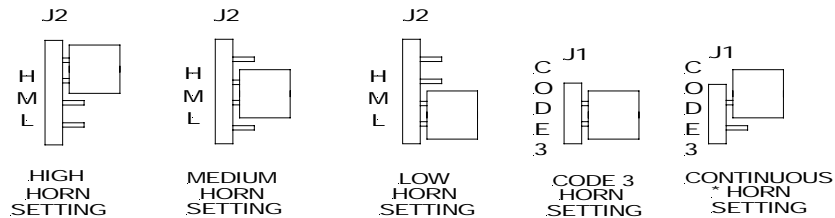

(Use needle nose pliers to pull and properly insert the jumper plug.)

No jumper plug is needed for continuous horn setting. However, it is recommended that the jumper plug be retained in the unit for future use (if needed) as shown in Figure 2.

**NOTE:** The Audible Horn must be set for code 3 when used with the sync module.

\* Continuous horn operation without sync module.

**WIRING INFORMATION:**

Figure 3:

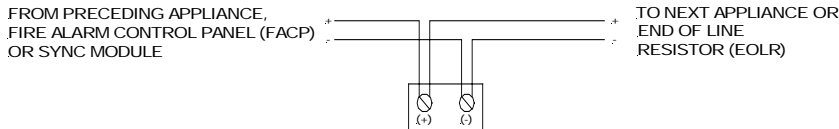
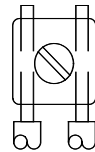

Figure 4:



Refer to Sync Module instruction sheets SM (P83123) DSM (P83177) and Wheelock’s Power Supplies for additional information.

1. AH-WP Appliances have in-out wiring terminals that accepts two #12 to #18 American Wire Gauge (AWG) wires at each screw terminal. Strip leads 3/8” inches for connection to screw terminals.
2. Break all in-out wire runs on supervised circuit supervision as shown in Figure 4. The polarity shown in the wiring diagrams is for the operation of the appliances. The polarity is reversed by the FACP during supervision.

**MOUNTING OPTIONS:**

**CAUTION:** The following figures show the maximum number of field wires (conductors) that can enter the backbox used with each mounting option. If these limits are exceeded, there may be insufficient space in the backbox to accommodate the field wires and stresses from the wires could damage the product.

Although the limits shown for each mounting option comply with the National Electrical Code (NEC), Cooper Wheelock recommends use of the largest backbox option shown and the use of approved stranded field wires, whenever possible, to provide additional wiring room for easy installation and minimum stress on the product from wiring.

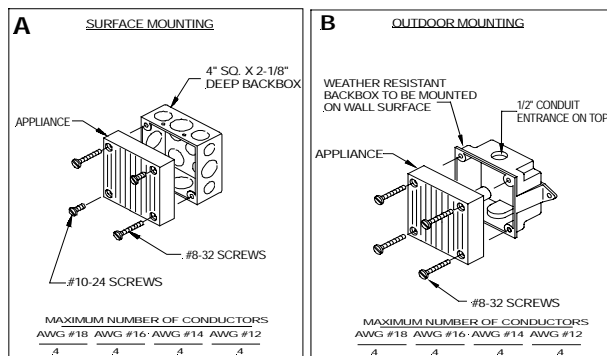

**MOUNTING NOTES:**

**CAUTION:** Check that the installed product will have sufficient clearance and wiring room prior to installing backboxes and conduit, especially if sheathed multiconductor cable or 3/4” conduit fittings are used.

1. For weather resistant installation, use outdoor mounting option.
2. All models can be surface mounted to a 4” square by 2-1/8” deep electrical backbox (Figure A) or a weatherproof backbox (Figure B).
3. Mounting hardware for each mounting option is supplied. For proper mounting, be sure to use the mounting screws supplied with the unit.
4. Conduit entrances to the backbox should be selected to provide sufficient wiring clearance for the installed product.
5. Use care and proper techniques to position the field wires in the backbox so that they use minimum space and produce minimum stress on the product. This is especially important for stiff heavy gauge wires with thick insulation or sheathing.
6. When terminating field wires, do not use more lead length than required. Excess lead length could result in insufficient wiring space for the signaling appliance.
7. Do not pass additional wires (used for other than the signaling appliance) through the backbox. Such additional wires could result in insufficient wiring space for the signaling appliance.
8. The knock-out opening on the backbox is sized for a 1/2” conduit and matching connector. Be sure that a proper watertight conduit fitting is used to connect the backbox for outdoor/severe environment applications.

These appliances can produce a distinctive three pulse Temporal Pattern Fire Alarm Evacuation Signal (for total evacuation) in accordance with NFPA 72.