



273 Branchport Ave.  
 Long Branch, N.J. 07740  
 (800) 631-2148  
 (800) 397-5777  
 www.cooperwheelock.com

*Thank you for using our products.*

**INSTALLATION INSTRUCTIONS  
 SERIES RSSWP STROBE WEATHERPROOF APPLIANCE  
 (WALL/CEILING MOUNT VERSION)**

*Use this product according to this instruction manual. Please keep this instruction manual for future reference.*

**GENERAL:**

Cooper Wheelock's Series RSSWP Strobes can provide a non-synchronized strobe signal when connected directly to a Fire Alarm Control Panel (FACP), or provide a synchronized strobe signal when used in conjunction with a Sync Module (SM), Dual Sync Module (DSM), or Cooper Wheelock's Power Supplies. The RSSWP strobe appliance is UL Listed under Standard 1638 (Visual Signaling Appliances) for indoor/outdoor use, fire protective service. The Series RSSWP Strobe Appliances are also ULC Listed under Standard CAN/ULC-S526-02 for Visual Signaling Appliances. RSSWP-2475W with color lens is UL Listed under Standard 1638 (Visual Signaling Appliance) for Private Mode Emergency and General Utility Signaling. The strobe has a 75 candela intensity on axis at -35°C and low current draw. For outdoor applications the RSSWP *must* be mounted to a Weatherproof Backbox (WPSBB). The strobes use a xenon flashtube with solid state circuitry enclosed in a polycarbonate lens to provide maximum visibility and reliability for effective visible signaling. All inputs are polarized for compatibility with standard reverse polarity supervision of circuit wiring by a FACP.

**NOTE:** All Canadian Installations should be in accordance with the Canadian Standard for the Installation of Fire Alarm Systems - CAN/ULC-S524-01 and Canadian Electrical Code, Part 1. Final acceptance is subject to authorities having jurisdiction (AHJ).

**⚠ WARNING: PLEASE READ THESE INSTRUCTIONS CAREFULLY. FAILURE TO COMPLY WITH ANY OF THE FOLLOWING INSTRUCTIONS, CAUTIONS AND WARNINGS COULD RESULT IN IMPROPER APPLICATION, INSTALLATION AND/OR OPERATION OF THESE PRODUCTS IN AN EMERGENCY SITUATION, WHICH COULD RESULT IN PROPERTY DAMAGE AND SERIOUS INJURY OR DEATH TO YOU AND/OR OTHERS.**

**⚠ CAUTION: NOT RECOMMENDED FOR USE AT REFRIGERATOR / FREEZER DOOR ENTRANCES OR OTHER AREAS WITH PERSISTENT CONDENSATION.**

**SPECIFICATIONS:**

<i>Table 1: UL/ULC Ratings</i>						
Model	Regulated Voltage (VDC/VRMS)	Voltage Range Limit Per UL 1638 (VDC/VRMS)	Voltage Range Per CAN/ULC-S526-02 (VDC/VRMS)	UL Rated Strobe Candela (cd)		ULC Rated Strobe Candela (cd)
				At 25°C	At -35°C	
RSSWP-2475W	24	16.0-33.0	20.0-31.0	180	75	180
RSSWP-2475C	24	16.0-33.0	20.0-31.0	180	75	180

The color Lens is not ULC approved.

**NOTES:**

1. Strobes will produce 1 flash per second over the "Regulated Voltage" range.
2. The RSSWP w/clear lens meet the required light distribution patterns defined in UL 1638 and ULC S526-02. The RSSWP with amber lens meet the required light distribution patterns defined in UL 1638.
3. All models are Listed for indoor and outdoor use with a temperature range of -31°F to +150°F (-35°C to +66°C) and maximum humidity of 95% RH. The effect of shipping and storage temperatures shall not adversely affect the performance of the appliance when it is stored in the original cartons and is not subjected to misuse or abuse.
4. Use RSSWP-2475W for wall and RSSWP-2475C for ceiling.
5. Candela ratings in Table 1 are for clear lens. Derate approximately 25% for amber, 55% for green, 70% for blue and 80% for red lens.

<i>Table 2: Current Ratings (AMPS)</i>		
Maximum RMS Current		
	Voltage	75cd
DC	16-33VDC	0.138
FWR	16-33VRMS	0.222

When calculating the total currents use Table 2 to determine the highest value of RMS current for an individual strobe, then multiply these values by the total number of strobes. Be sure to add the currents for any other appliances, including audible signaling appliances powered by the same source, and to include any required safety factors.

**NOTE:** The maximum number of strobes on a single notification appliance circuit shall not exceed 50.

**⚠ CAUTION:** These notification appliances are UL Listed as “Regulated”. They are intended to be used with FACP’s whose notification circuits are UL Listed as “Regulated.” These appliances shall not be used on UL Listed “Special Application” notification circuits unless the appliances are identified to be compatible in the installation instructions of the FACP or unless the FACP is identified to be compatible in this instruction manual.

**⚠ WARNING:** THESE APPLIANCES WERE TESTED TO THE REGULATED VOLTAGE LIMITS OF 16.0-33.0 VOLTS FOR 24V MODELS USING FILTERED DC OR UNFILTERED FULL-WAVE-RECTIFIED VOLTAGE. DO NOT APPLY VOLTAGE OUTSIDE OF THIS RANGE.

**⚠ WARNING:** CHECK THE MINIMUM AND MAXIMUM OUTPUT OF THE POWER SUPPLY AND STANDBY BATTERY AND SUBTRACT THE VOLTAGE DROP FROM THE CIRCUIT WIRING RESISTANCE TO DETERMINE THE APPLIED VOLTAGE TO THE STROBES. THE MAXIMUM WIRE IMPEDANCE BETWEEN STROBES SHALL NOT EXCEED 35 OHMS.

**⚠ CAUTION:** Strobes are not designed to be used on coded systems in which the applied voltage is cycled on and off.

**⚠ WARNING:** MAKE SURE THAT THE TOTAL RMS CURRENT REQUIRED BY ALL APPLIANCES THAT ARE CONNECTED TO THE SYSTEM’S PRIMARY AND SECONDARY POWER SOURCES, NOTIFICATION APPLIANCE CIRCUITS, SM, DSM SYNC MODULES, OR COOPER WHEELOCK POWER SUPPLIES DOES NOT EXCEED THE POWER SOURCES’ RATED CAPACITY OR THE CURRENT RATINGS OF ANY FUSES ON THE CIRCUITS TO WHICH THESE APPLIANCES ARE WIRED. OVERLOADING POWER SOURCES OR EXCEEDING FUSE RATINGS COULD RESULT IN LOSS OF POWER AND FAILURE TO ALERT OCCUPANTS DURING AN EMERGENCY, WHICH COULD RESULT IN PROPERTY DAMAGE AND SERIOUS INJURY OR DEATH TO YOU AND/OR OTHERS.

**WIRING AND MOUNTING INFORMATION:**

**⚠ CAUTION:** The following figure shows the maximum number of field wires (conductors) that can enter the backbox used with each mounting option. If these limits are exceeded, there may be insufficient space in the backbox to accommodate the field wires and stresses from the wires could damage the product.

**⚠ CAUTION:** Check that the installed product will have sufficient clearance and wiring room prior to installing backboxes and conduit, especially if sheathed multiconductor cable is used.

Although the limits shown for each mounting option comply with the National Electrical Code (NEC), Cooper Wheelock recommends use of the largest backbox option shown and the use of approved stranded field wires, whenever possible, to provide additional wiring room for easy installation and minimum stress on the product from wiring.

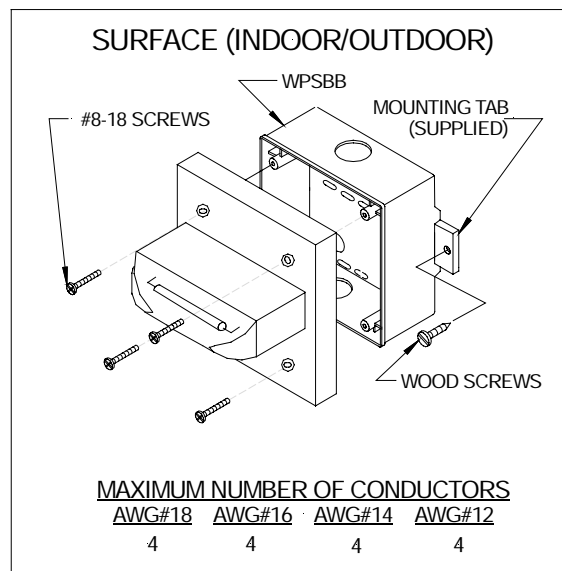

**⚠ WARNING:** THIS UNIT MUST BE MOUNTED ON A FLAT SURFACE, SO THAT THE SURFACE COVERS THE ENTIRE BACK SURFACE OF THE BACKBOX. WHEN USED IN AN OUTDOOR APPLICATION OR A NEMA 3R APPLICATION, USE WEATHER PROOF RATED CONDUIT FITTING ON ALL KNOCKOUTS OF THE BACKBOX.

Figure 1: Wiring Diagram

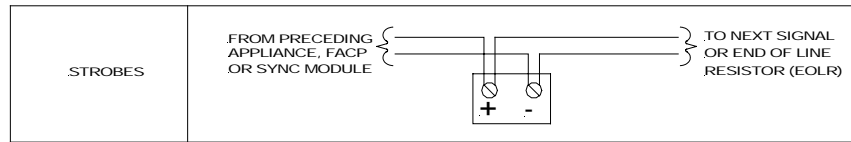
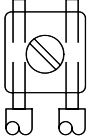

Figure 2:



- All strobes have in-out wiring terminals that accepts two #12 to #18 American Wire Gauge (AWG) wires at each screw terminal. Strip leads 3/8 inches and connect to screw terminals.
- Break all in-out wire runs on supervised circuits to assure integrity of circuit supervision as shown in Figure 2. The polarity shown in the wiring diagrams is for the operation of the appliances. The polarity is reversed by the FACP during supervision.

Refer to instruction sheets for SM (P83123), DSM (P83177) or Cooper Wheelock power supplies for additional information.

1. The knock-out opening on the backbox is sized for a 1/2" conduit and matching connector. Be sure that a proper watertight conduit fitting is used to connect the backbox for outdoor/severe environment applications. Conduit entrances to the backbox should be selected to provide sufficient wiring clearance for the installed product. Do not pass additional wires (used for other than the signaling appliance) through the backbox. Such additional wires could result in insufficient wiring space for the signaling appliance.
2. When terminating field wires, do not use more lead length than required. Excess lead length could result in insufficient wiring space for the appliance.
3. Use care and proper techniques to position the field wires in the backbox so that they use minimum space and produce minimum stress on the product. This is especially important for stiff, heavy gauge wires and wires with thick insulation or sheathing.
4. Connect 4 field wires to the RSSWP terminal block (polarity must be observed).
5. Bend the 4 field wires up 90° at the connection to the terminal block, then carefully push the 4 field wires into the backbox by hand.
6. Carefully press the RSSWP to the backbox, verifying that the RSSWP is in contact with the gasket all the way around. It should not be resting on the lip of the backbox.
7. Screw the RSSWP to the WPSBB using the #8-18 screws supplied.

**⚠ WARNING: REMOVAL OF THE PRINTED CIRCUIT BOARD COVER AT THE BACK OF THE MOUNTING PLATE COULD RESULT IN SEVERE ELECTRIC SHOCK.**

**⚠ WARNING: THE RSSWP STROBE APPLIANCE IS A "FIRE ALARM DEVICE - DO NOT PAINT."**

**⚠ WARNING: WHEN INSTALLING STROBES IN AN OPEN OFFICE OR OTHER AREAS CONTAINING PARTITIONS OR OTHER VIEWING OBSTRUCTIONS, SPECIAL ATTENTION SHOULD BE GIVEN TO THE LOCATION OF THE STROBES SO THAT THEIR OPERATING EFFECT CAN BE SEEN BY ALL INTENDED VIEWERS, WITH THE INTENSITY, NUMBER, AND TYPE OF STROBES BEING SUFFICIENT TO MAKE SURE THAT THE INTENDED VIEWER IS ALERTED BY PROPER ILLUMINATION. FAILURE TO DO SO COULD RESULT IN PROPERTY DAMAGE AND SERIOUS INJURY OR DEATH TO YOU AND/OR OTHERS.**

**⚠ WARNING: A SMALL POSSIBILITY EXISTS THAT THE USE OF MULTIPLE STROBES WITHIN A PERSON'S FIELD OF VIEW, UNDER CERTAIN CIRCUMSTANCES, MIGHT INDUCE A PHOTO-SENSITIVE RESPONSE IN PERSONS WITH EPILEPSY. STROBE REFLECTIONS IN A GLASS OR MIRRORRED SURFACE MIGHT ALSO INDUCE SUCH A RESPONSE. TO MINIMIZE THIS POSSIBLE HAZARD, COOPER WHEELOCK STRONGLY RECOMMENDS THAT THE STROBES INSTALLED SHOULD NOT PRESENT A COMPOSITE FLASH RATE IN THE FIELD OF VIEW WHICH EXCEEDS FIVE (5) Hz AT THE OPERATING VOLTAGE OF THE STROBES. COOPER WHEELOCK ALSO STRONGLY RECOMMENDS THAT THE INTENSITY AND COMPOSITE FLASH RATE OF INSTALLED STROBES COMPLY WITH LEVELS ESTABLISHED BY APPLICABLE LAWS, STANDARDS, REGULATIONS, CODES AND GUIDELINES.**

**NOTE:** NFPA 72/ANSI 117.1 conform to ADAAG Equivalent Facilitation Guidelines in using fewer, higher intensity strobes within the same protected area.

**⚠ CAUTION:** Check the installation instructions of the manufacturers of other equipment used in the system for any guidelines or restrictions on wiring and/or locating Notification Appliance Circuits (NAC) and notification appliances. Some system communication circuits and/or audio circuits, for example, may require special precautions to assure immunity from electrical noise (e.g. audio crosstalk).

**NOTE:** This equipment has been tested and found to comply with the limits for a Class B digital device, pursuant to Part 15 of the FCC Rules. These limits are designed to provide reasonable protection against harmful interference in residential installation. This equipment generates, uses and can radiate radio frequency energy and, if not installed and used in accordance with the instructions, may cause harmful interference to radio communications. However, there is no guarantee that interference will not occur in a particular installation. If this equipment does cause harmful interference to radio or television reception, which can be determined by turning the equipment off and on, the user is encouraged to try to correct the interference by one or more of the following measures: 1) Reorient or relocate the receiving antenna, 2) Increase the separation between the equipment and receiver, 3) Connect the equipment into an outlet on a circuit different from that to which the receiver is connected, and 4) Consult the dealer or an experienced radio/TV technician for help.

**ANY MATERIAL EXTRAPOLATED FROM THIS DOCUMENT OR FROM COOPER WHEELOCK MANUALS OR OTHER DOCUMENTS DESCRIBING THE PRODUCT FOR USE IN PROMOTIONAL OR ADVERTISING CLAIMS, OR FOR ANY OTHER USE, INCLUDING**